

Inhoudsopgave

Achteras Aandrijving	60
Achteras Huis	44
Dashbord & Stuur	28
Differentieel Slot	62
Driepunt & Trekhaak	90
Elektrisch Midden & Achter	72
Elektrisch Voor & rond Motor	70
Gaskabels Hand & Voetgas	8
Hef Deksel & Cilinder	76
Hydrauliek Stuur	74
Hydrauliek Systeem	78
Hydrauliek Ventielen	84
Index	98
Koppeling & Pedaal	48
Luchtfilters	12
Middenstuk Knik & Centrale As	40
Motor 30 CV	4
Motor 40CV	6
Motorkap & Bumper	16
PTO Schakeling	68
PTO & Tanwielen	66
Radiator & Slangen	10
Rem Pedaal & Handrem	52
Remmen	50
Rolbeugels	22
Schakelpoken & Gaffels	58
Spatschermen & Voet Platen	18
Stickers	26
Tandwielen	56
Tandwielen	54
Tank	14
Vooras Aandrijving	46
Vooras Huis	38
Wielen	94
Zitting	30

Code	Description	Notes
A0101_1_18484	ENGINE (30 CV)	
A0102_1_18510	ENGINE (40 CV)	
A0201_1_18536	ENGINE CONTROLS	
A0301_1_47945	COOLER	
A0401_1_18577	AIR FILTER	
A0501_2_47963	FUEL TANK	
B0101_2_18644	BODY	
B0202_2_18795	MUD-GUARDS AND FLOOR BOARDS	
B0202_5_49540	MUD-GUARDS AND FLOOR BOARDS	
B0401_2_48226	PLATES	
B0501_2_48249	DASHBOARD AND STEERING WHEEL	
B0601_1_18928	SEAT "SEAT"	
B0602_1_49108	SEAT "MT"	
B0603_0_51086	SEAT (KAB)	
B0701_1_18971	SEAT CONNECTION	
C0102_1_19033	FRONT AXLE	
C0202_2_48288	INTERMEDIATE SECTION	
C0301_1_19119	REAR AXLE	
D0102_1_19161	FRONT TRANSMISSION	
D0201_2_48405	CLUTCH	
D0301_1_19222	BRAKES	
D0401_1_48440	BRAKES CONTROL UNITS	
D0501_1_19263	MAIN SHAFT AND CORRESPONDING GEARS	
D0601_1_19281	TRANSMISSION SHAFT GEARS	
D0701_2_48498	CHANGE GEAR CONTROLS	
D0801_1_19338	REAR TRANSMISSION	
D0901_1_19362	DIFFERENTIAL GEAR LOCK	
D1001_2_48472	POWER TAKE-OFF	
D1101_1_19419	POWER TAKE-OFF CONTROLS	
E0101_4_49162	FRONT ELECTRICAL SYSTEM	
E0201_2_49124	BATTERY AND REAR ELECTRICAL SYSTEM	
F0102_1_19533	STEERING HYDRAULIC SYSTEM	
G0101_1_19551	HYDRAULIC LIFT	
G0202_2_48619	HYDRAULIC SYSTEM	

Code	Description	Notes
G0203_1_48686	2ND LIFTING HYDRAULIC JACK	
G0302_1_19731	ONE ADDITIONAL CONTROL VALVE FOR "AR"	
G0303_1_19742	TWO OR THREE ADDITIONAL CONTROL VALVES FOR "AR"	
I0101_1_19774	AUXILIARY CONTROL VALVES	
L0101_1_19795	ATTACHMENT HITCH	
L0201_0_19826	DRAWBAR "EEC" TYPE APPROVED	
M0102_2_48797	WHEELS AND TYRES (TABLE 1/2)	
M0201_1_49600	WHEELS AND TYRES (TABLE 2/2)	



MOTORE "LDW 1003 / B3" - 3 CILINDRI
"LDW 1003 / B3" ENGINE - 3 CYLINDERS
MOTEUR "LDW 1003 / B3" - 3 CYLINDRES
"LDW 1003 / B3" MOTOR - 3 ZYLINDERN
MOTOR "LDW 1003 / B3" - 3 CILINDROS

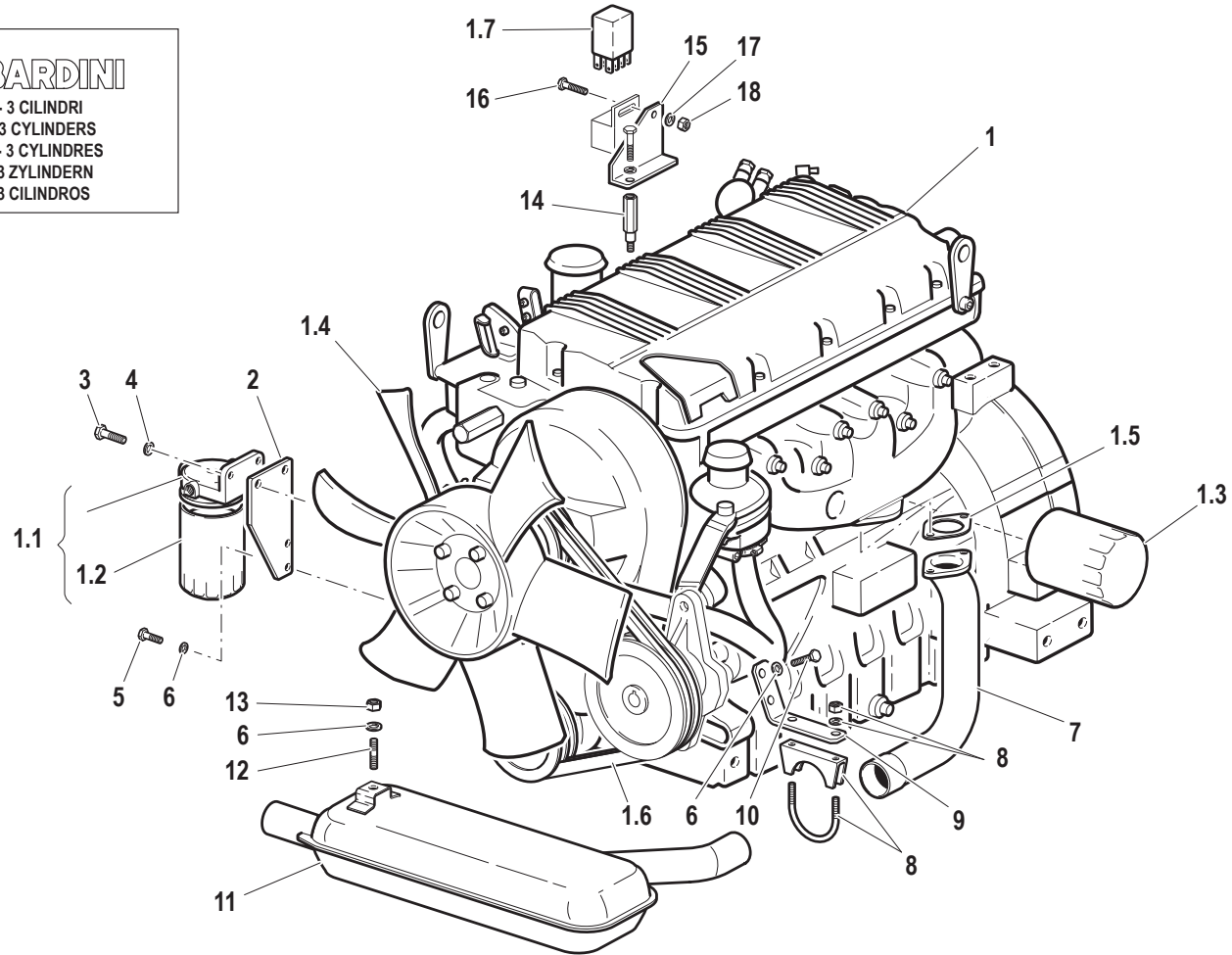

Pos.	Code	Q.ty	Description	Notes
1	41N40003	0	MOT LOMB LDW1003/B3 K2A44C1 *	
1.1	59900192	0	FUEL FILTER	
1.2	59900193	0	FILTER INSERT	
1.3	59900223	0	OIL FILTER	
1.4	59900227	0	FAN	
1.5	58171633	0	FLANGE	
1.6	59900222	0	ENGINE BELT	
1.7	F0834378001	0	CENTRAL PROCESSING UNIT	
2	56173058	0	FILTER SUPPORT	
3	31112219	0	SCREW TE M10X25 UNI 5739	
4	31411105	0	WASHER 10,5x21	
5	31112148	0	SCREW TE M8X18 UNI 5739 8G	
6	F0843643060	0	WASHER 8	
7	59073007	0	EXHAUST MANIFOLD	
8	58173010	0	COLLAR	
9	56173009	0	RETAINER	
10	31112147	0	SCREW TE M8X18 UNI 5739 8G	
11	58173616	0	EXHAUST SILENCER	
12	F0838131000	0	STUD BOLT M8X20 UNI 5911 8.8	
13	31211080	0	NUT M8	
14	56173204	0	SMALL COLUMN	
15	56173065	0	SUPPORT	
16	F0861929060	0	SCREW M5X12 UNI 5739	
17	F0843561000	0	WASHER 5	
18	F0814525000	0	NUT M5	



MOTORE (40 CV)
ENGINE (40 CV)
MOTEUR (40 CV)
MOTOR (40 CV)
MOTOR (40 CV)

Tavola	Rev.	Data
A.01.02	1	04/2002

1/1

RS	AR
•	•



MOTORE "LDW 1404 / B3" - 4 CILINDRI
"LDW 1404 / B3" ENGINE - 4 CYLINDERS
MOTEUR "LDW 1404 / B3" - 4 CYLINDRES
"LDW 1404 / B3" MOTOR - 4 ZYLINDERN
MOTOR "LDW 1404 / B3" - 4 CILINDROS

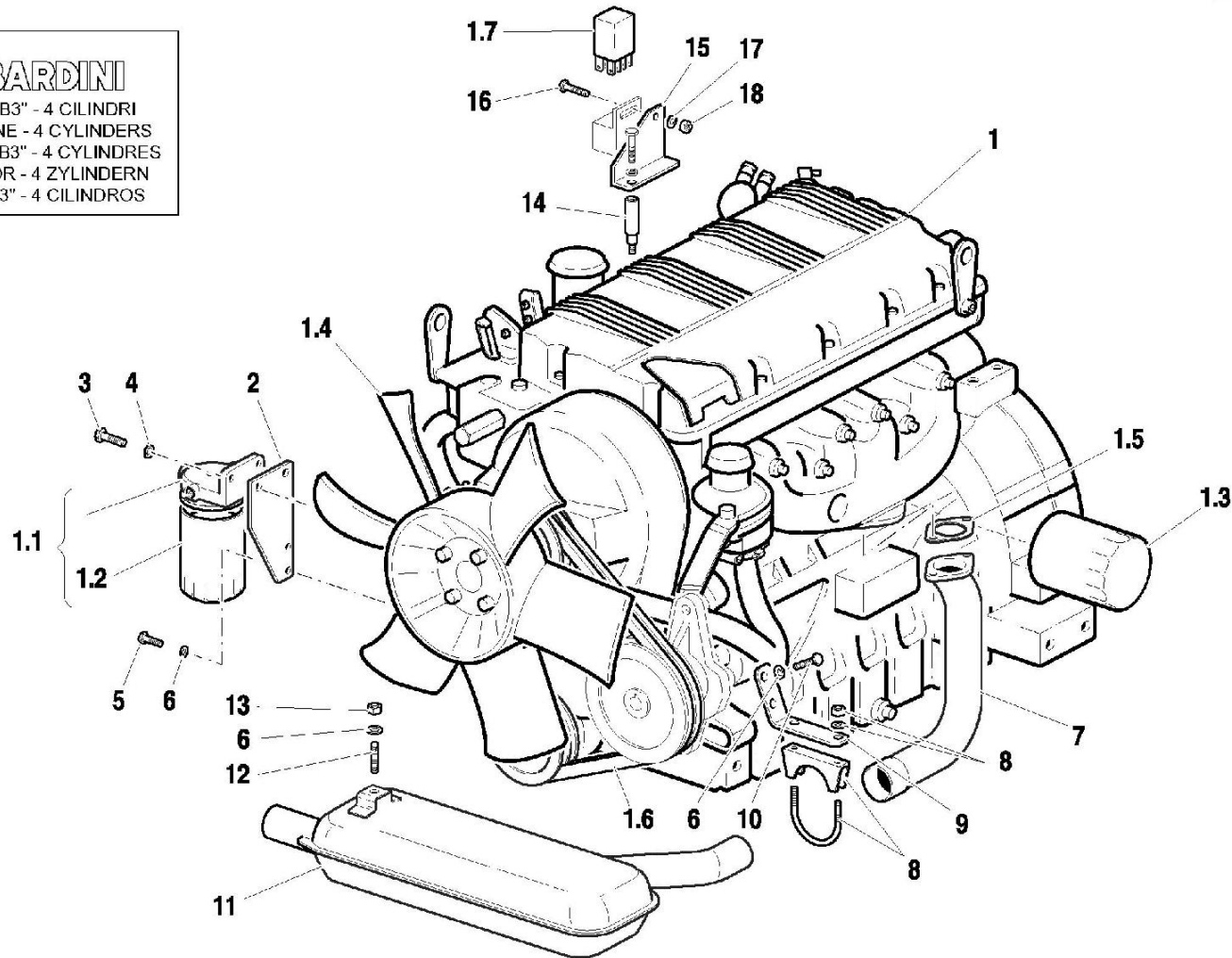

(REV. 1/02)

Pos.	Code	Q.ty	Description	Notes
1	41N50003	0	MOT LOMB LDW1404/B3 K2A46C1 *	
1.1	59900192	0	FUEL FILTER	
1.2	59900193	0	FILTER INSERT	
1.3	59900194	0	OIL FILTER	
1.4	58173442	0	FAN	
1.5	58171633	0	FLANGE	
1.6	59900222	0	ENGINE BELT	
1.7	F0834378001	0	CENTRAL PROCESSING UNIT	
2	56173058	0	FILTER SUPPORT	
3	31112219	0	SCREW TE M10X25 UNI 5739	
4	31411105	0	WASHER 10,5x21	
5	31112148	0	SCREW TE M8X18 UNI 5739 8G	
6	F0843643060	0	WASHER 8	
7	59073008	0	EXHAUST MANIFOLD	
8	58173010	0	COLLAR	
9	56173009	0	RETAINER	
10	31112147	0	SCREW TE M8X18 UNI 5739 8G	
11	58173616	0	EXHAUST SILENCER	
12	F0838131000	0	STUD BOLT M8X20 UNI 5911 8.8	
13	31211080	0	NUT M8	
14	56173204	0	SMALL COLUMN	
15	56173065	0	SUPPORT	
16	F0861929060	0	SCREW M5X12 UNI 5739	
17	F0843561000	0	WASHER 5	
18	F0814525000	0	NUT M5	

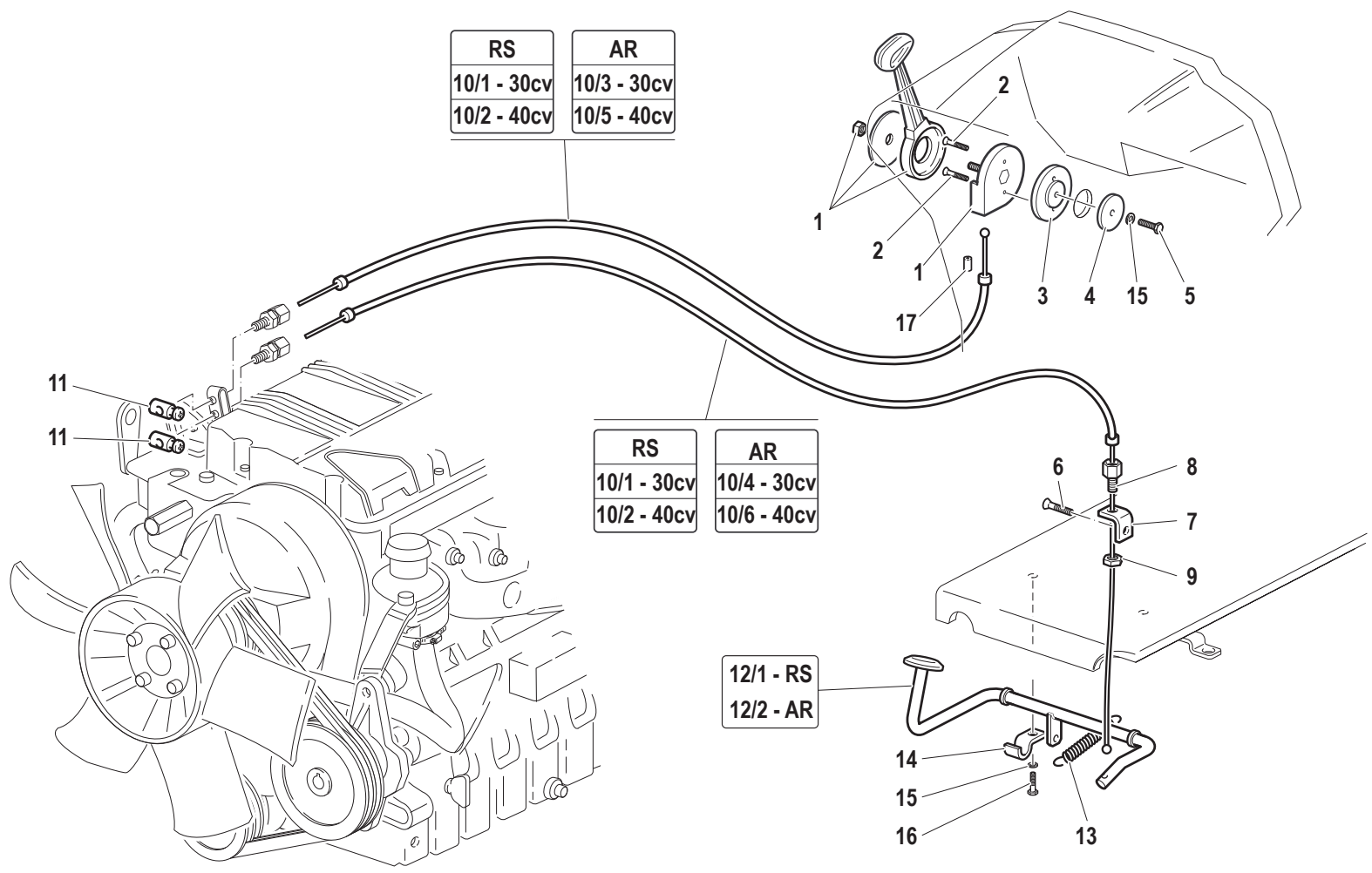

Pos.	Code	Q.ty	Description	Notes
1	F0828029070	0	ACCELERATOR	
2	31132562	0	SCREW TSVEI M6X16 UNI 5933	
3	56171877	0	FLANGE	
4	56171883	0	LOCK WASHER D.45x9/4	
5	31112150	0	SCREW TE M8X20 UNI 5739 8G	
6	31132566	0	SCREW TSVEI M8X20 UNI 5933	
7	56172929	0	PLATE	
8	F0858021000	0	REGISTER	
9	31231080	0	NUT M8	
10/1	58072931	0	CABLE	
10/2	58073085	0	CABLE	
10/3	58072074	0	CABLE	
10/4	58072492	0	CABLE	
10/5	58072075	0	CABLE	
10/6	58070489	0	CABLE	
11	58048002	0	CLAMPING SCREW	
12/1	59072903	0	ACCEL. PEDAL	
12/2	59073429	0	ACCEL. PEDAL	
13	58073227	0	SPRING	
14	56071768	0	PLATE	
15	F0843643060	0	WASHER 8	
16	31112148	0	SCREW TE M8X18 UNI 5739 8G	
17	F0858520000	1	SLEEVE	

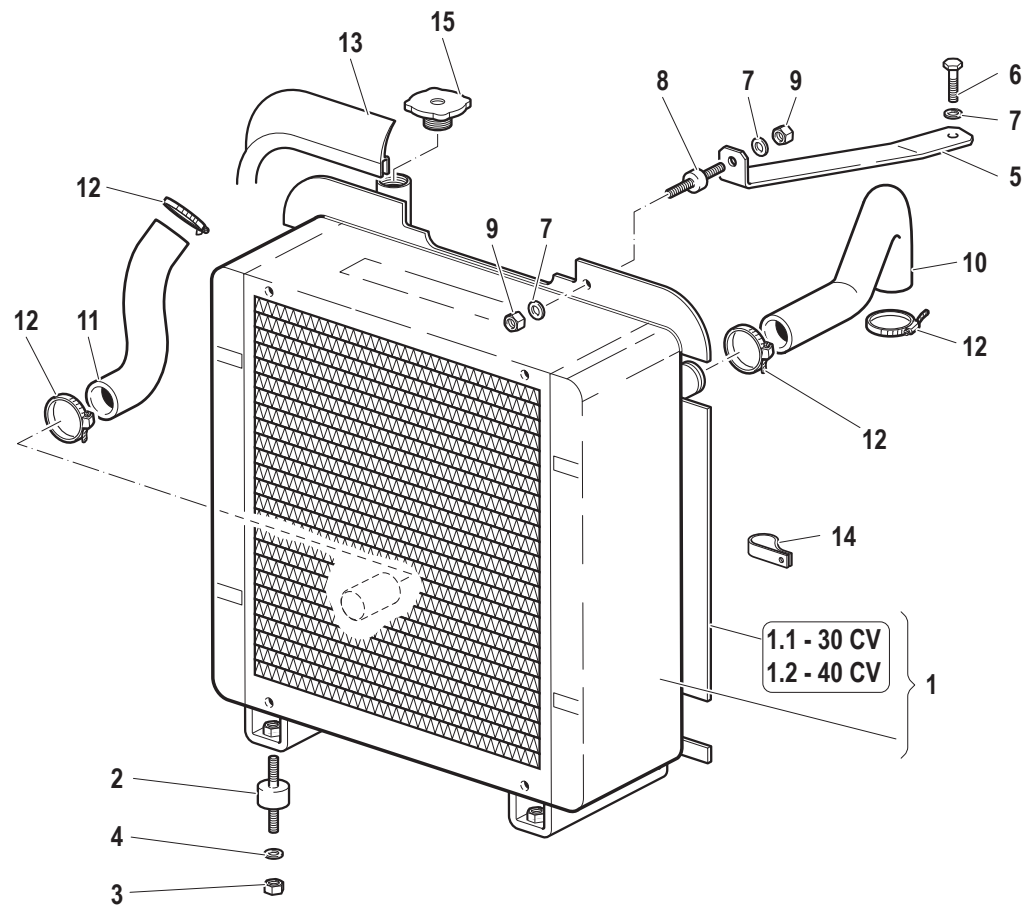

Pos.	Code	Q.ty	Description	Notes
1	58178704	1	RADIATOR	
1.1	58175052	1	DUCT	
1.2	58175051	1	DUCT	
2	58174093	2	SILENT-BLOCK	
3	31211080	2	NUT M8	
4	F0843643060	2	WASHER 8	
5	56173012	1	BRACKET	
6	31112090	1	SCREW TE M6X16 UNI 5739 8G	
7	F0843570000	3	WASHER 6	
8	F0849206005	1	SILENT-BLOCK	
9	31211060	2	NUT M6	
10	55172995	1	SLEEVE	
11	55172994	1	SLEEVE	
12	F0817523010	4	CLAMP	
13	F0256809050	1	GASKET	
14	F0825415050	1	CLAMP	
15	59900540	1	COOLER PLUG	



FILTRO ARIA
AIR FILTER
FILTRE A AIR
LUFTFILTER
FILTRO DE AIRE

Tavola	Rev.	Data
A.04.01	1	04/2002

1/1

RS	AR
•	•

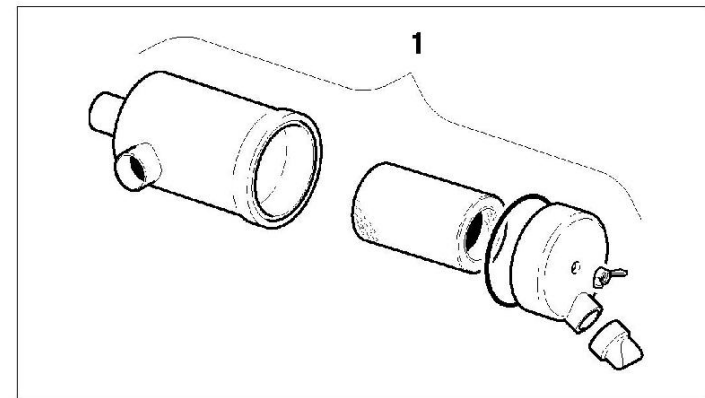
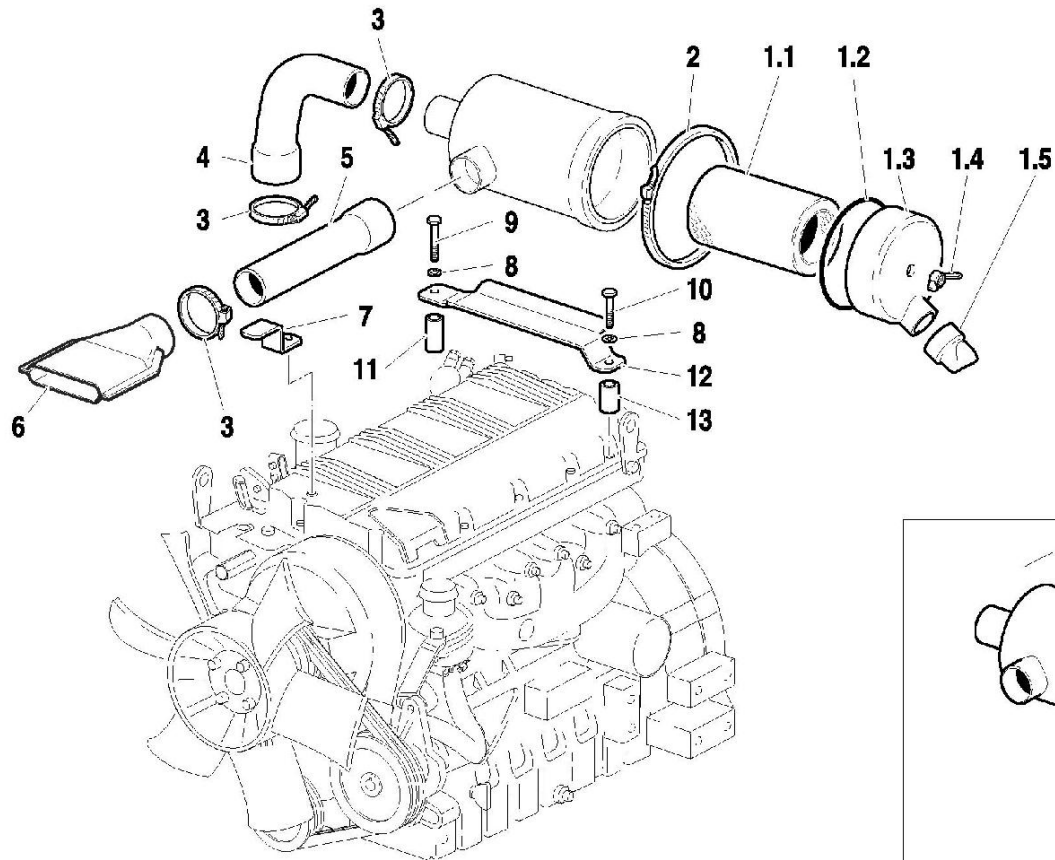

Pos.	Code	Q.ty	Description	Notes
1	58172996	0	AIR FILTER	
1.1	58172999	0	CARTOUCHE	
1.2	59900217	0	GASKET	
1.3	59900218	0	COVER	
1.4	59900219	0	FLOAT LEVEL	
1.5	59900220	0	VALVE	
2	F0817603000	0	CLAMP	
3	F0817568000	0	CLAMP	
4	55172997	0	SLEEVE	
5	56172998	0	PIPE	
6	57371825	0	SOCKET	
7	56173013	0	RETAINER	
8	F0843570000	0	WASHER 6	
9	31111097	0	SCREW TE M6X45 UNI 5737 8G	
10	31112082	0	SCREW TE M6X12 UNI 5739 8G	
11	56172992	0	SPACER	
12	56172985	0	RETAINER	
13	56172993	0	SPACER	

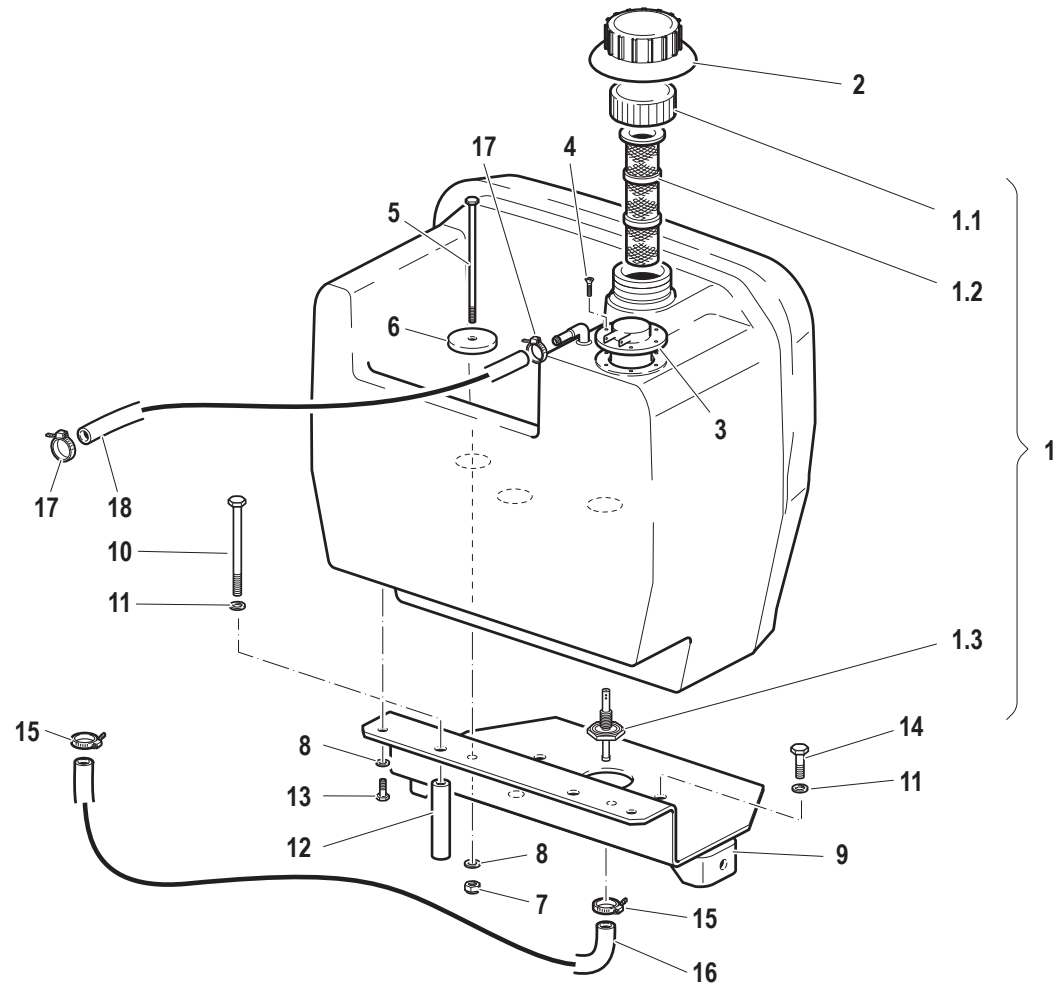

Pos.	Code	Q.ty	Description	Notes
1	55273089	1	FUEL TANK	
1.1	F0849500001	1	TANK COVER	
1.2	F0849500002	1	FILTER	
1.3	57174884	1	PIPE FITTING	
2	57371900	1	LINING	
3	58173187	1	CONTROL	
4	F0861867050	1	SCREW M4,2X19 DIN 7981	
5	F0863097070	1	SCREW M8X170 UNI 5737	
6	56170275	1	SPACER	
7	31241080	1	SELFLOCK NUT M8	
8	F0843643060	1	WASHER 8	
9	59073090	1	TANK SUPPORT	
10	31112224	1	SCREW TE M10X130 UNI 5737	
11	F0843755000	1	WASHER 10	
12	56171775	1	SPACER	
13	31112147	1	SCREW TE M8X18 UNI 5739 8G	
14	31112210	1	SCREW TE M10X20 UNI 5739	
15	F0817512000	1	CLAMP	
16	58073237	1	PIPE	
17	F0817505000	1	CLAMP	
18	58073238	1	FLEXIBLE HOSE	

 400051 →

1/1 - 30 CV - RS
1/2 - 40 CV - RS
1/3 - 30 CV - AR
1/4 - 40 CV - AR

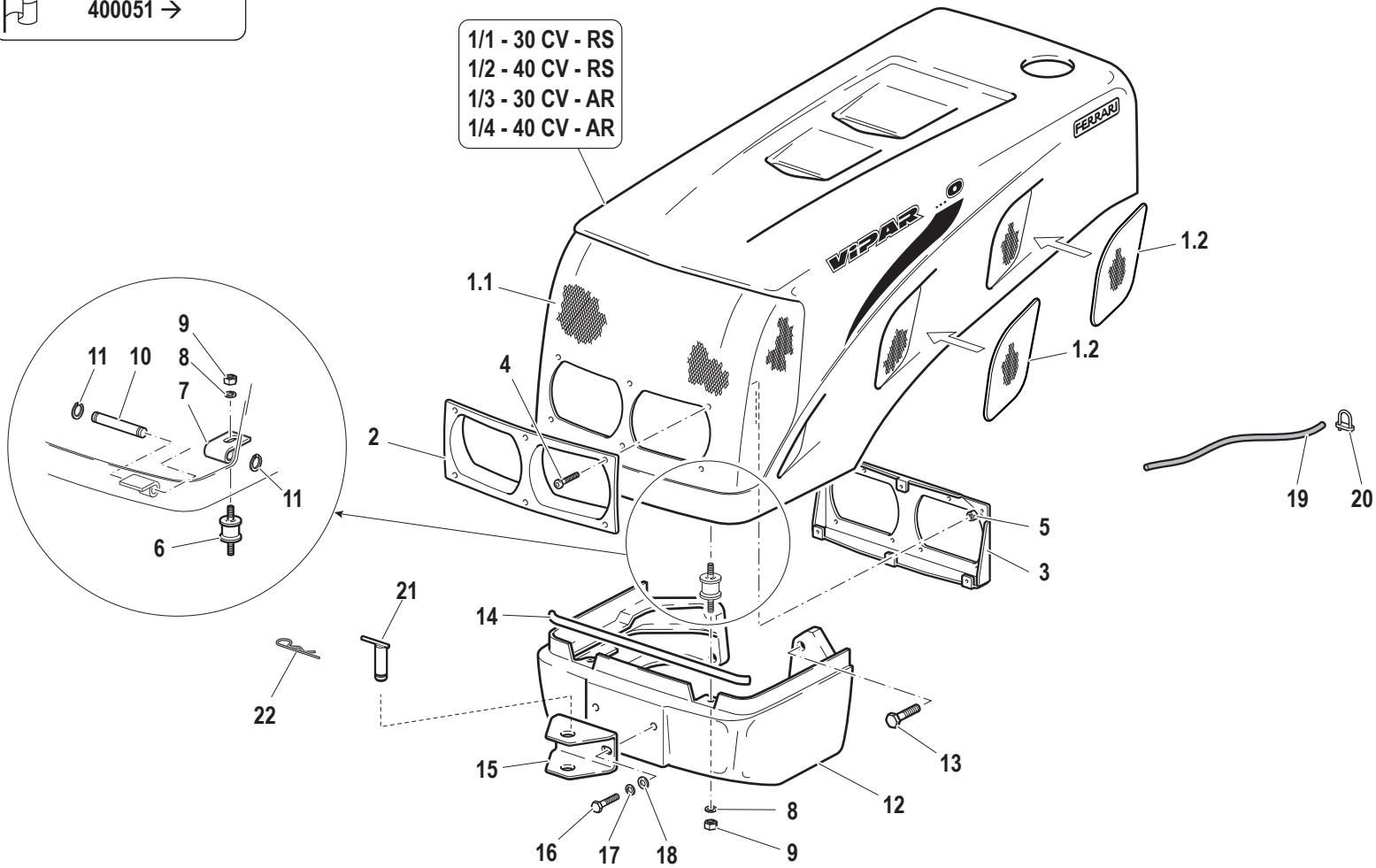

Pos.	Code	Q.ty	Description	Notes
1.1	56177693	1	FRONT GRILL	
1/1	59900267	0	COMPLETE HOOD	
1/2	59900268	0	COMPLETE HOOD	
1.2	56174427	0	FRONT GRILL	
1/3	59900269	0	BONNET	
1/4	59900270	0	COMPLETE HOOD	
2	57373097	0	FRONT GRILLE	
3	59073098	0	SUPPORT	
4	F0862479040	0	SCREW M6X20 7380	
5	F0814647000	0	NUT M10	
6	F0849211010	0	SILENT-BLOCK	
7	56071684	0	BRACKET	
8	F0843755000	0	WASHER 10	
9	F0814629010	0	NUT M10	
10	56071681	0	HINGE PIN	
11	35211060	0	SEEGER RING E 6 UNI 7434	
12	51172965	0	FRONT SUPPORT	
13	F0863951000	0	SCREW M12X45 UNI 5737	
14	F0256910000	0	FOAM PROFILE 5X20	
15	56174873	0	TOW HOOK	
16	31112272	0	SCREW TE M12X30 UNI 5739	
17	F0843843060	0	WASHER 12	
18	31411130	0	WASHER 13x24	
19	F0252929002	0	CRATE	
20	F0859070030	1	TERMINAL	
21	59075283	1	PIN	
22	F0851497000	1	SPLIT PIN	

RS	AR
	•

400051 →

- STAFFA FISSAGGIO LEVA FRENO RIMORCHIO
- TRAILER BRAKES LEVER FIXING BRACKET
- BRIDE DU LEVIER DES FREINS DE LA REMORQUE
- ANHÄNGERBREMSHEBEL BEFESTIGUNGSBÜGEL
- ESTRIBO FIJACION PALANCA FRENO DE LO REMOLQUE

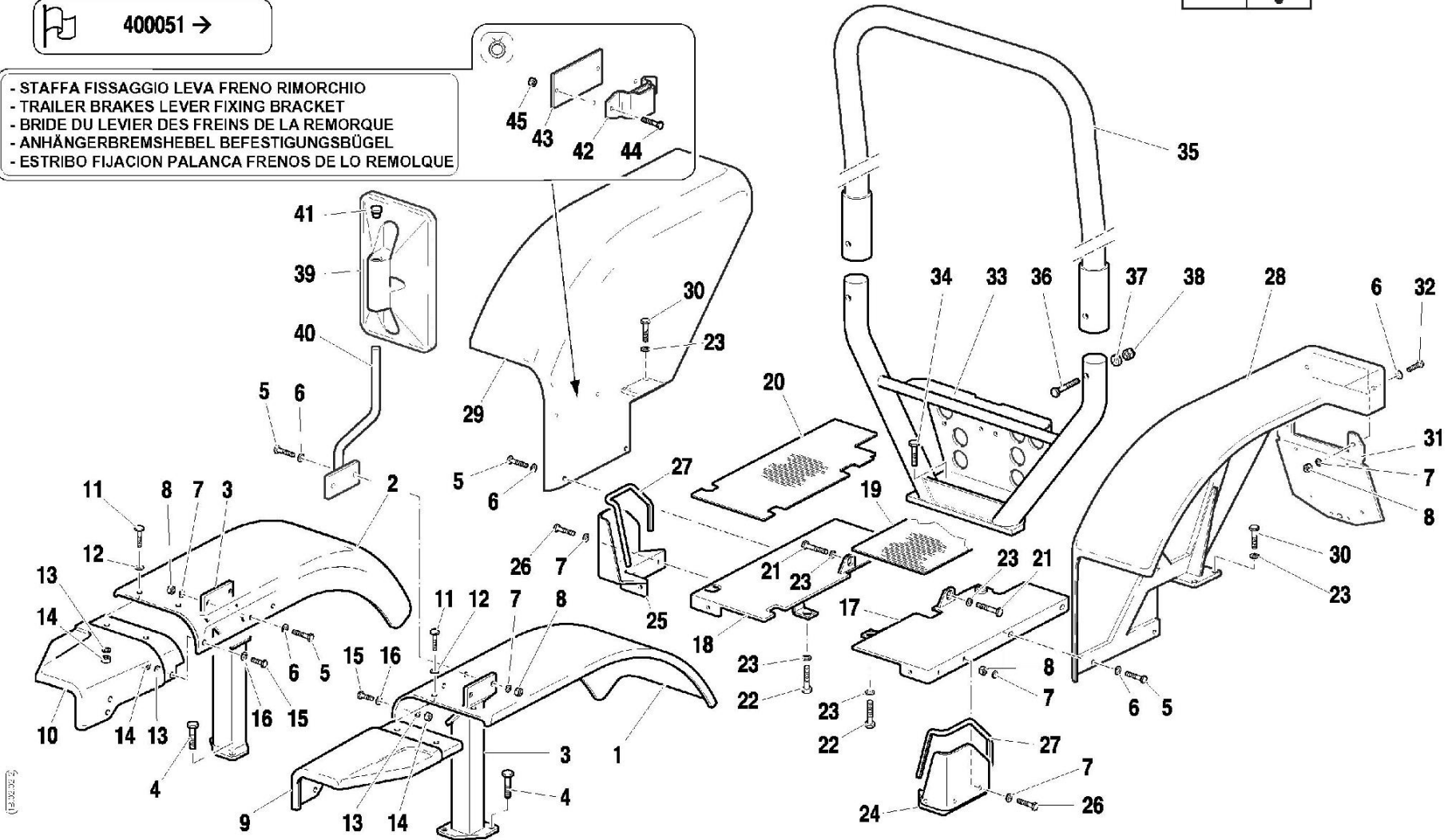

20000000

Pos.	Code	Q.ty	Description	Notes
1	59074862	0	LEFT FRONT FENDER	
2	59074863	0	RIGHT FRONT FENDER	
3	59073888	0	CONNECTION	
4	31112271	0	SCREW TE M12X25 UNI 5739	
5	31112153	0	SCREW TE M8X35 UNI 5739 8G	
6	31411084	0	WASHER 8,4x17	
7	F0843643060	0	WASHER 8	
8	F0814574000	0	NUT M8	
9	57373746	0	SUPPORT	
10	57373745	0	SUPPORT	
11	31121560	0	SCREW TTQ M6X20 UNI 5731	
12	F0843570000	0	WASHER 6	
13	31411064	0	WASHER 6,4x12,5	
14	31211060	0	NUT M6	
15	31112087	0	SCREW TE M6X22 UNI 5739 8G	
16	31424064	0	SPRING WASHER 6,4	
17	59073430	0	LEFT FOOTBOARD	
18	59073431	0	RIGHT FOOTBOARD	
19	57374207	0	FOOTREST COVER	
20	57374208	0	FOOTREST COVER	
21	31112210	0	SCREW TE M10X20 UNI 5739	
22	31112211	0	SCREW TE M10X30 UNI 5739	
23	F0843755000	0	WASHER 10	
24	56073439	0	FRONT DEFLECTOR	
25	56073438	0	FRONT DEFLECTOR	
26	31112148	0	SCREW TE M8X18 UNI 5739 8G	
27	F0256808000	0	FLAT BAND	
28	59073128	0	LEFT REAR FENDER	
29	59073129	0	RIGHT REAR FENDER	
30	31112219	0	SCREW TE M10X25 UNI 5739	
31	59073139	0	PLATE HOLDER	
32	31111151	0	SCREW TE M8X16 UNI 5739 8G	
33	59072940	0	SUPPORT	
34	31112254	0	SCREW TE M12X30UNI5739	

SERIAL

MUD-GUARDS AND FLOOR BOARDS

CODE REV

B0202_2_18795

RS	AR
	•

400051 →

- STAFFA FISSAGGIO LEVA FRENO RIMORCHIO
- TRAILER BRAKES LEVER FIXING BRACKET
- BRIDE DU LEVIER DES FREINS DE LA REMORQUE
- ANHÄNGERBREMSHEBEL BEFESTIGUNGSBÜGEL
- ESTRIBO FIJACION PALANCA FRENO DE LO REMOLQUE

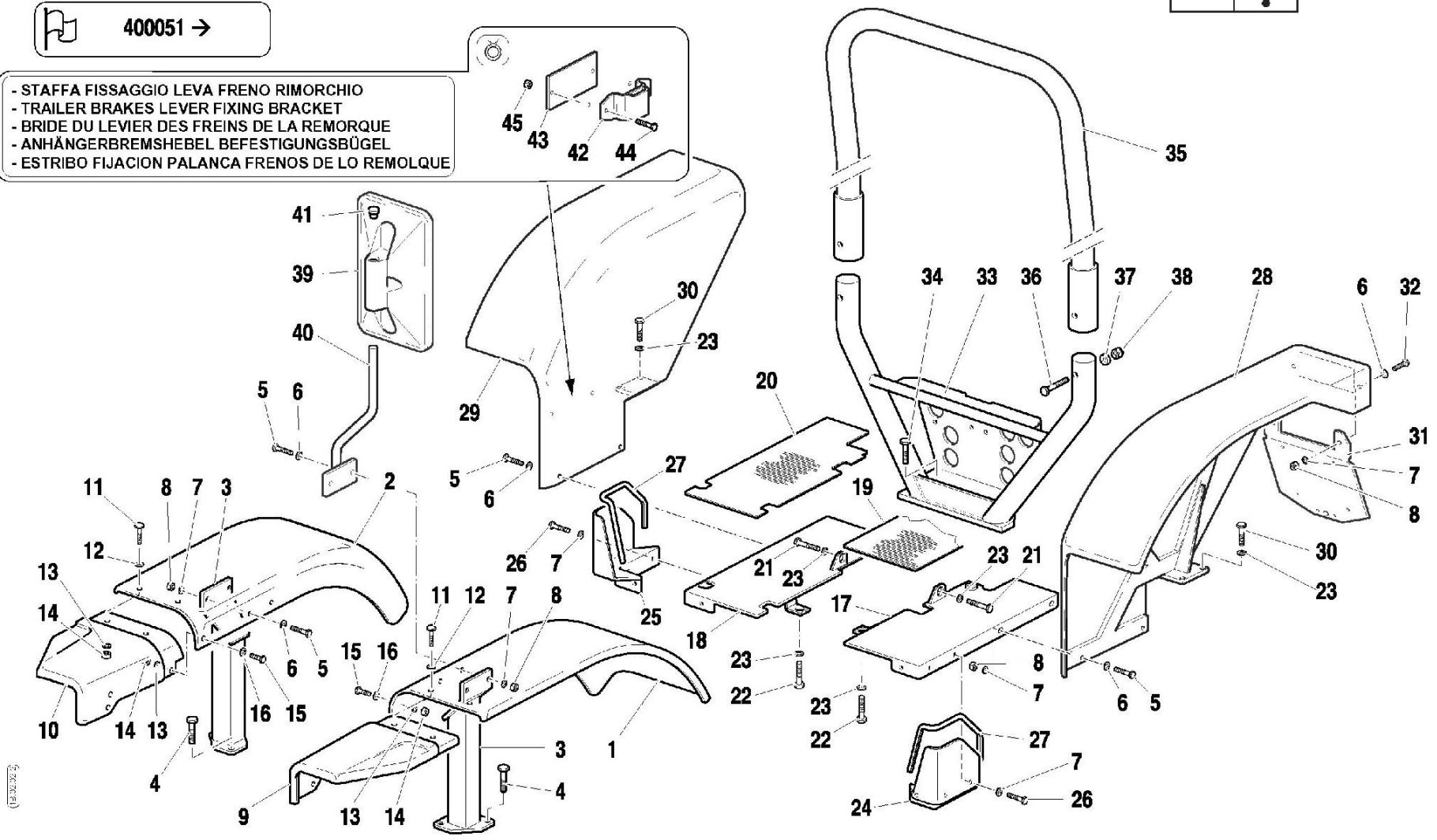

Pos.	Code	Q.ty	Description	Notes
35	59072945	0	SAFETY ROLL BAR	
36	31112293	0	SCREW TE M12X80 UNI 5737	
37	56172964	0	SPACER	
38	58170634	0	SELFLOCK NUT M12	
39	30000514	0	REAR VIEW MIRROR	
40	59073799	0	SUPPORT	
41	58170968	0	PLUG	
42	59070592	0	LEVER BEARING	
43	56172129	0	BRACKET FASTENER	
44	31112219	0	SCREW TE M10X25 UNI 5739	
45	F0814642020	0	SELFLOCK NUT M10	

- STAFFA FISSAGGIO LEVA FRENO RIMORCHIO
- TRAILER BRAKES LEVER FIXING BRACKET
- BRIDE DU LEVIER DES FREINS DE LA REMORQUE
- ANHÄNGERBREMSHEBEL BEFESTIGUNGSBÜGEL
- ESTRIBO FIJACION PALANCA FRENOS DE LO REMOLQUE

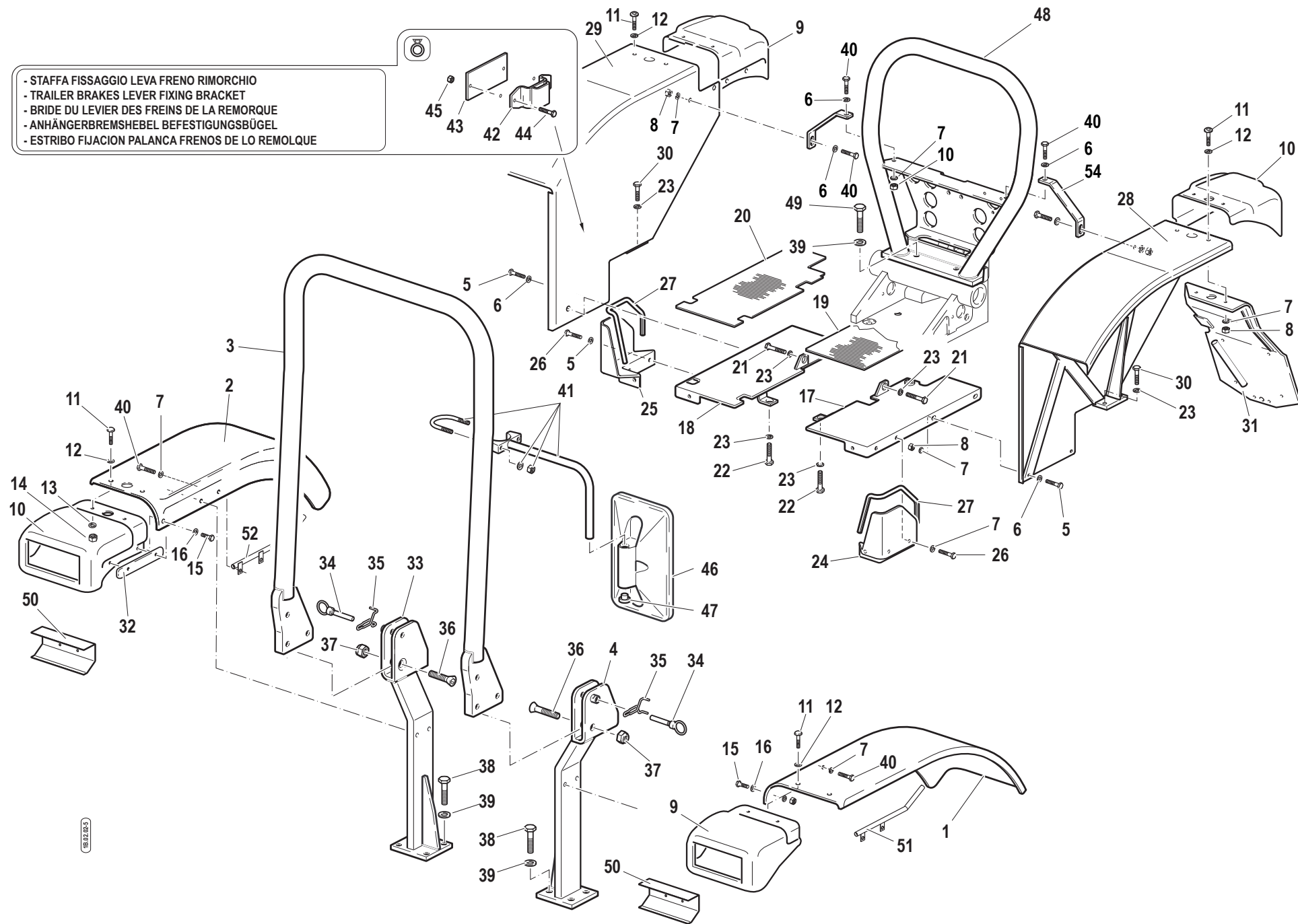

BRZ/202

Pos.	Code	Q.ty	Description	Notes
1	59075504V	1	LEFT FRONT FENDER	
2	59075508V	1	RIGHT FRONT FENDER	
3	59074144	1	SAFETY ROLL BAR	
4	59074140	1	SUPPORT	
5	31112153	4	SCREW TE M8X35 UNI 5739 8G	
6	31411084	10	WASHER 8,4x17	
7	F0843643060	16	WASHER 8	
8	F0814574000	10	NUT M8	
9	57375344	1	SUPPORT	
10	57375345	1	SUPPORT	
11	31121560	4	SCREW TTQ M6X20 UNI 5731	
12	F0843570000	4	WASHER 6	
13	31411064	6	WASHER 6,4x12,5	
14	31211060	6	NUT M6	
15	31112087	2	SCREW TE M6X22 UNI 5739 8G	
16	31424064	2	SPRING WASHER 6,4	
17	59073430	1	LEFT FOOTBOARD	
18	59073431	1	RIGHT FOOTBOARD	
19	57374207	1	FOOTREST COVER	
20	57374208	1	FOOTREST COVER	
21	31112210	2	SCREW TE M10X20 UNI 5739	
22	31112211	2	SCREW TE M10X30 UNI 5739	
23	F0843755000	8	WASHER 10	
24	56073439	1	FRONT DEFLECTOR	
25	56073438	1	FRONT DEFLECTOR	
26	31112148	6	SCREW TE M8X18 UNI 5739 8G	
27	F0256808000	1	FLAT BAND	
28	59078975V	1	LEFT REAR FENDER	
29	59078980V	1	RIGHT REAR FENDER	
30	31112219	4	SCREW TE M10X25 UNI 5739	
31	59075490	1	LICENCE PLATE HOLD	
32	56174135	2	FIXING BRACKET	
33	59074141	1	SUPPORT	
34	56175540	2	HINGE PIN	

SERIAL

MUD-GUARDS AND FLOOR BOARDS

CODE REV

B0202_5_49540

- STAFFA FISSAGGIO LEVA FRENO RIMORCHIO
- TRAILER BRAKES LEVER FIXING BRACKET
- BRIDE DU LEVIER DES FREINS DE LA REMORQUE
- ANHÄNGERBREMSHEBEL BEFESTIGUNGSBÜGEL
- ESTRIBO FIJACION PALANCA FRENS DE LO REMOLQUE

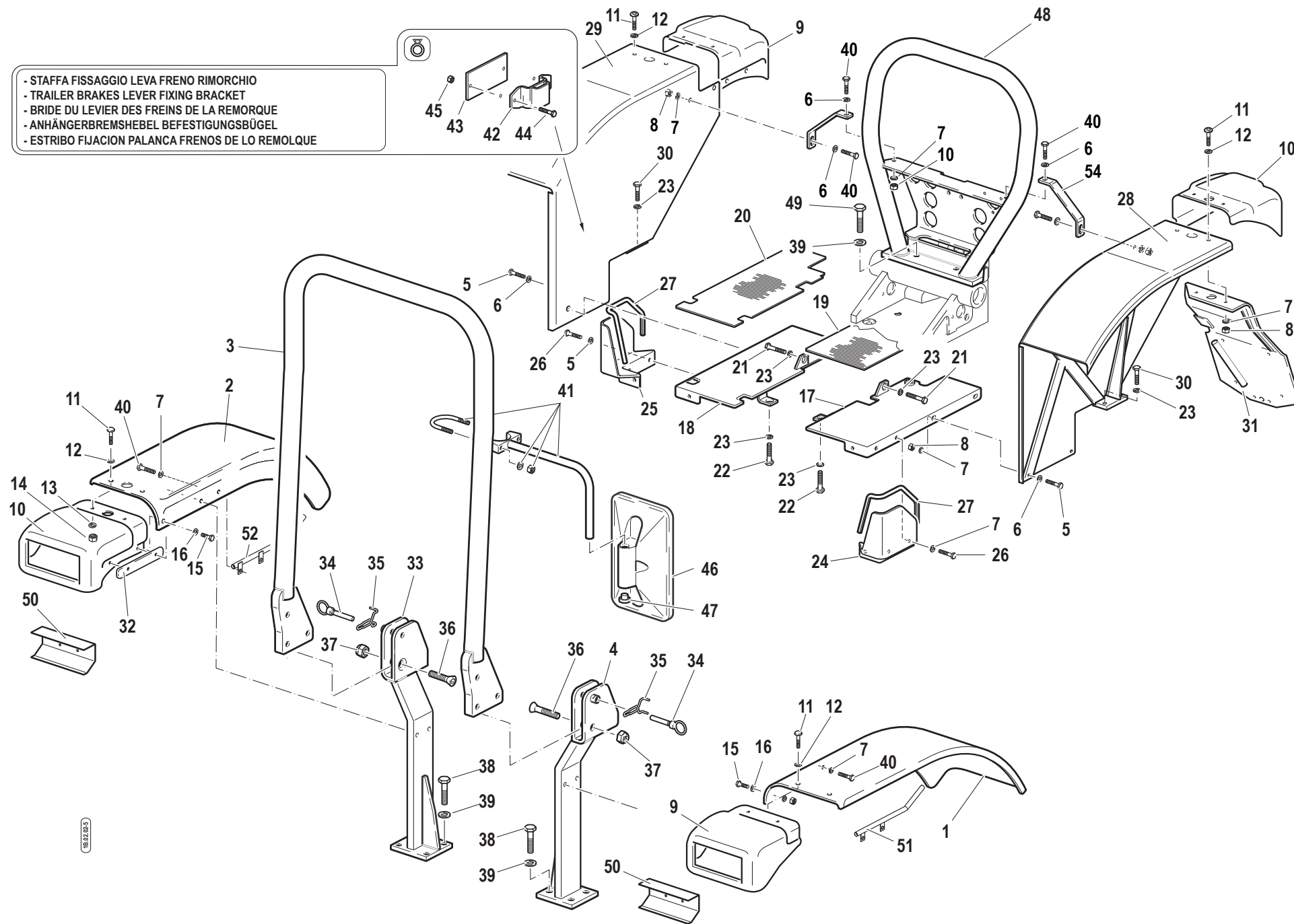

Pos.	Code	Q.ty	Description	Notes
35	58070097	2	SPRING	
36	F0864309100	2	SCREW M14X60 UNI 5933	
37	31241140	2	SELFLOCK NUT M14	
38	31112272	8	SCREW TE M12X30 UNI 5739	
39	F0843843060	12	WASHER 12	
40	31112151	8	SCREW TE M8X25 UNI 5739 8G	
41	59070591	1	SUPPORT	
42	59070592	1	LEVER BEARING	
43	56172129	1	BRACKET FASTENER	
44	31112219	2	SCREW TE M10X25 UNI 5739	
45	F0814642020	2	SELFLOCK NUT M10	
46	30000514	1	REAR VIEW MIRROR	
47	58170968	1	PLUG	
48	59072114	1	SAFETY ROLL BAR	
49	31112264	4	SCREW TE M12X35 UNI 5739	
50	56171938	2	BRACKET	
51	59076413	1	CABLE BARRIER RAIL	
52	59076414	1	CABLE BARRIER RAIL	
53	59078986	2	SUPPORTING YOKE	

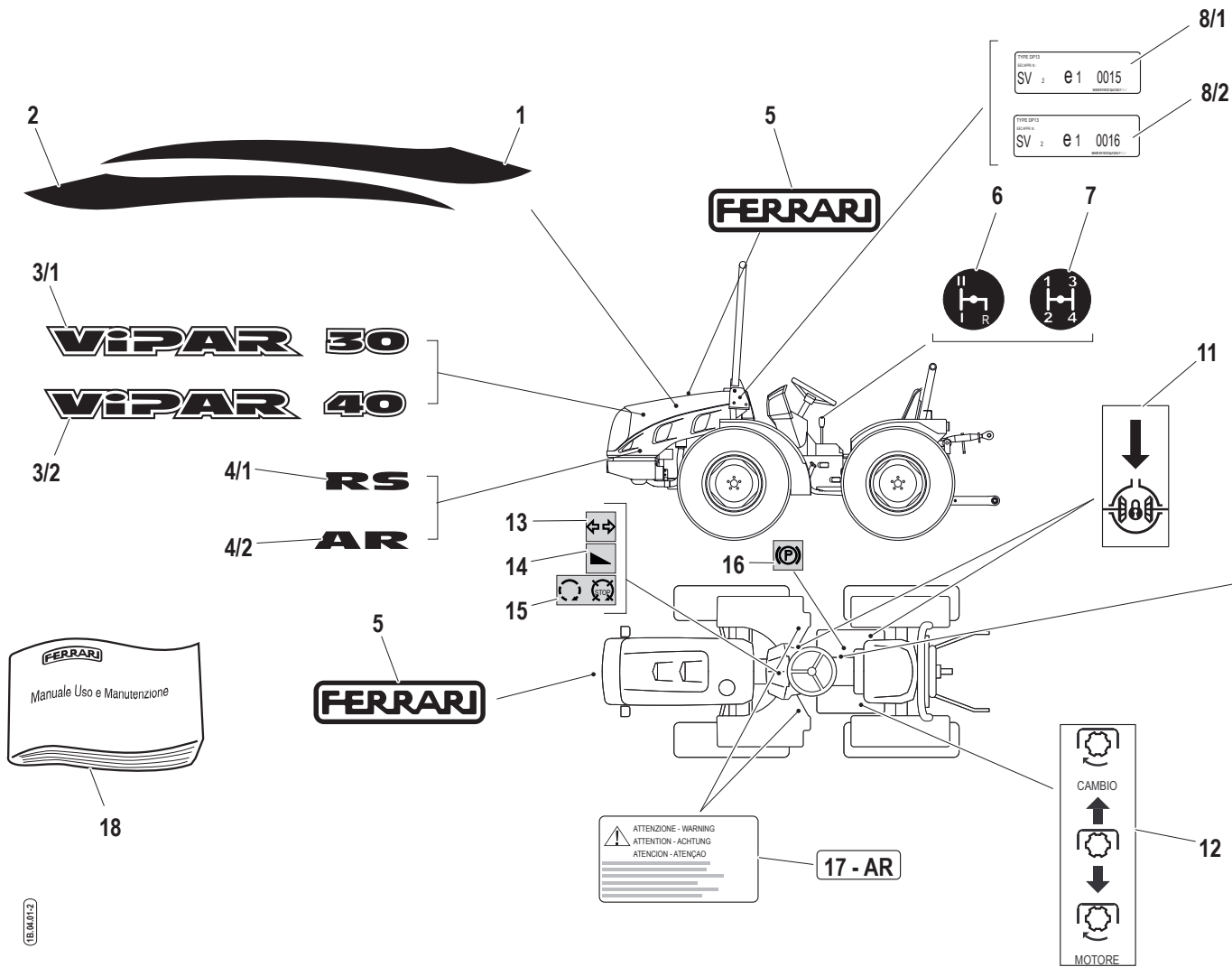

TIPO DPT
SV : e1 0015

TIPO DPT
SV : e1 0016

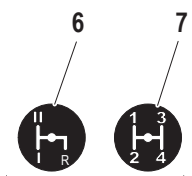

Made by BCS S.p.a. - Abbadegrasso Italy
STABILIMENTO di LUZZARA (RE)

TIPO

OMOLOGAZIONE NUMERO

NUMERO DI IDENTIFIC.

MASSA MAX AMMISSIBILE KG

MASSA MAX ASSE ANTERIORE KG

MASSA MAX ASSE POSTERIORE KG

SENZA FRENI AD INERZIA		CON FRENI INDIPENDENTI	
MASSA MASSIME RIMORCHIABILI (KG)	CON FRENI	CON FRENI	ASSISTITA

COEFF. DI ASSORBIMENTO m-1

CORRETTO (SECONDO DIRETTIVA CEE 77/537)

ANNO

Pos.	Code	Q.ty	Description	Notes
1	58073549	1	DECAL	
2	58073548	1	DECAL	
3/1	58073550	2	DECAL	
3/2	58073551	2	DECAL	
4/1	58073553	2	DECAL	
4/2	58073552	2	DECAL	
5	58073554	3	DECAL	
6	58074224	1	DECAL	
7	58074225	1	DECAL	
8/1	58074562	1	PLATE	
8/2	58074563	1	PLATE	
9	58072737	1	PLATE	
10	F0808518050	4	RIVET 3,5x6,5	
11	58072520	2	INSTRUCTION PLATE	
12	58072575	1	PLATE	
13	58072509	1	INSTRUCTION PLATE	
14	58072517	1	INSTRUCTION PLATE	
15	58072511	1	INSTRUCTION PLATE	
16	58072510	1	INSTRUCTION PLATE	
17	58073156	2	PLATE	
18	F0907170109	1	TECHN. MANUAL VIPAR	

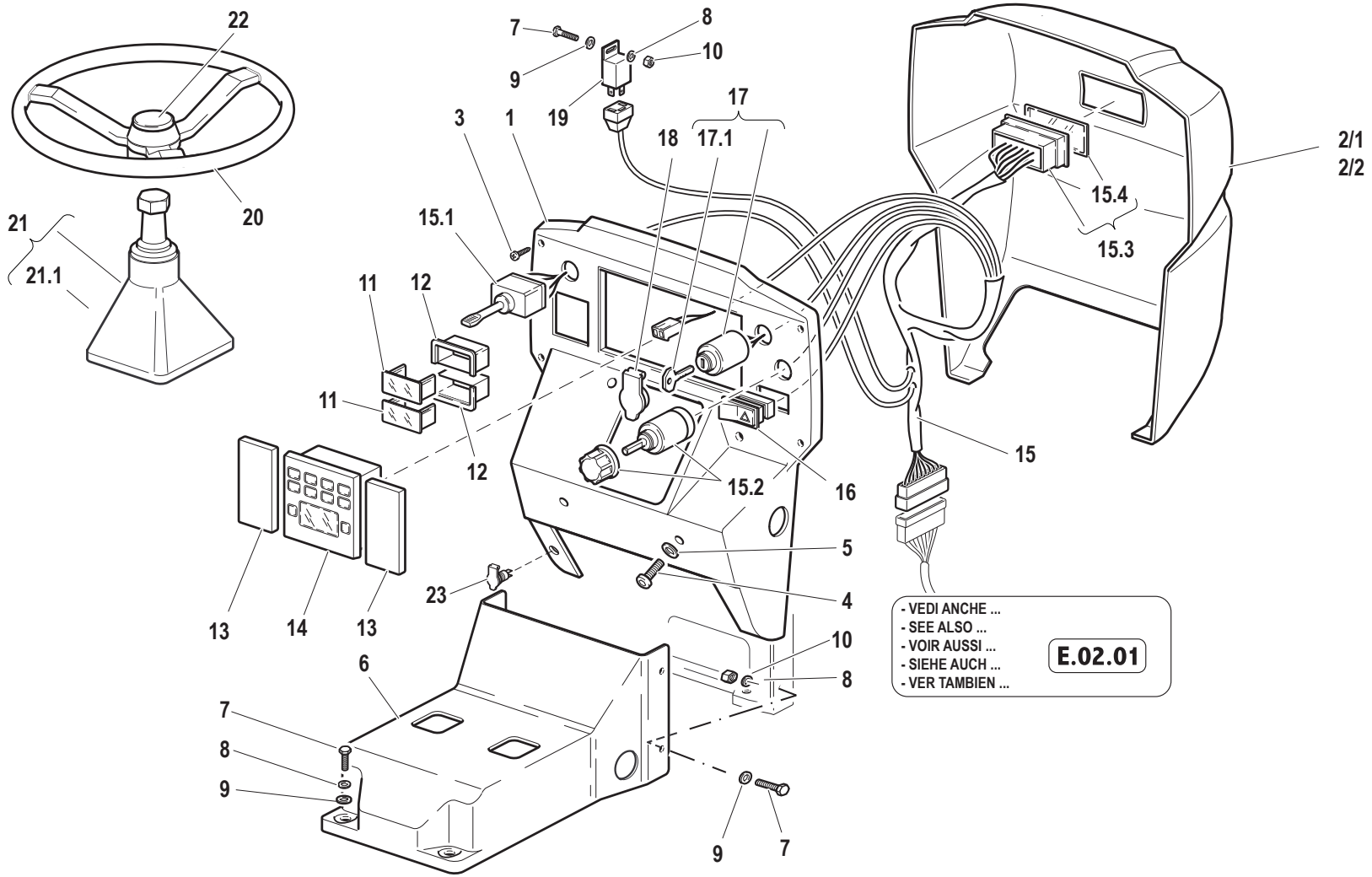

Pos.	Code	Q.ty	Description	Notes
1	55274441	1	INSTRUMENT PANEL	
2/1	55271852	1	INSTRUMENT PANEL	
2/2	55271644	1	INSTRUMENT PANEL	
3	31510053	1	RIBBED SCREW TC 4,8X32	
4	F0862479020	1	SCREW M8X16 7380	
5	31411084	1	WASHER 8,4x17	
6	57374196	1	COVER	
7	31112090	1	SCREW TE M6X16 UNI 5739 8G	
8	F0843570000	1	WASHER 6	
9	31411064	1	WASHER 6,4x12,5	
10	31211060	1	NUT M6	
11	58172043	1	FRONT GRILLE	
12	58170376	1	TERMINAL FOR SWITCH	
13	57373101	1	COVER	
14	58173108	1	GAUGE	
15	58077816	1	CABLE	
15.1	F0825436000	1	SWITCH	
15.2	F0825436003	1	SWITCH	
15.3	58170453	1	FUSE BOX	
15.4	58172267	1	COVER	
16	F0825115010	1	PUSH-BUTTON	
17	30000614	1	PANEL	
17.1	F0825500220	1	KEY	
18	F0825400060	1	COVER	
19	F0825139000	1	FLASHER	
20	F0865040000	1	STEERING WHEEL	
21	F0865475000	1	SMALL COLUMN	
21.1	57372600	1	COVER	
22	F0865040010	1	PLUG	
23	F0825403050	1	SOCKET	

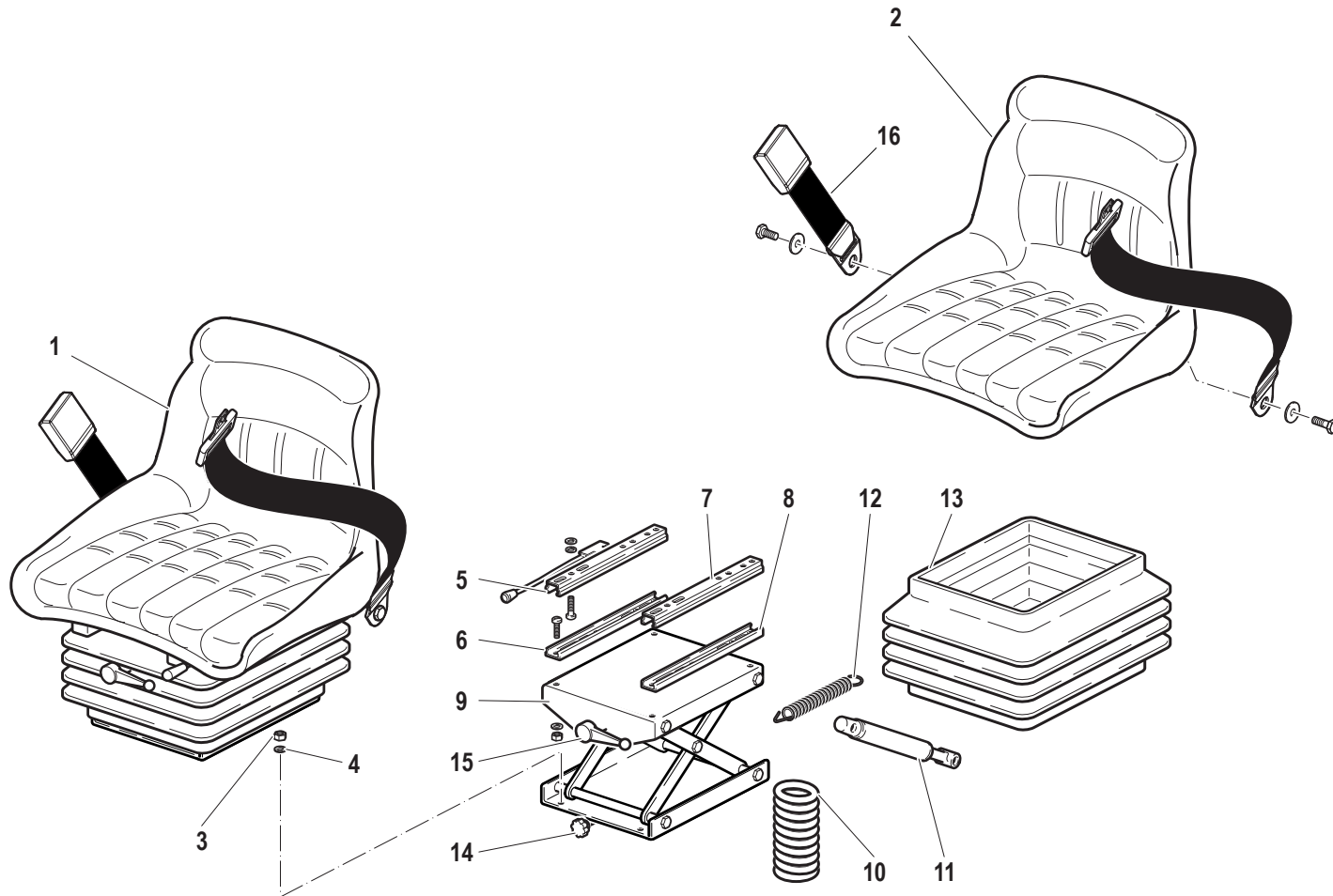

Pos.	Code	Q.ty	Description	Notes
1	58177728	1	SEAT	
2	59900171	0	SEAT CAVITY	
3	F0814569000	0	NUT M8 UNI 5589 CL:8	
4	31411084	0	WASHER 8,4x17	
5	59900172	0	GUIDE	
6	59900173	0	GUIDE	
7	59900174	0	GUIDE	
8	59900175	0	GUIDE	
9	59900163	0	SPRING	
10	59900168	0	SPRING	
11	59900169	0	SHOCKS ABSORBER	
12	59900167	0	SPRING	
13	59900170	0	BELLOWS	
14	59900166	0	HAND WHEEL	
15	59900165	0	LEVER	
16	59901266	1	SAFETY BELT	

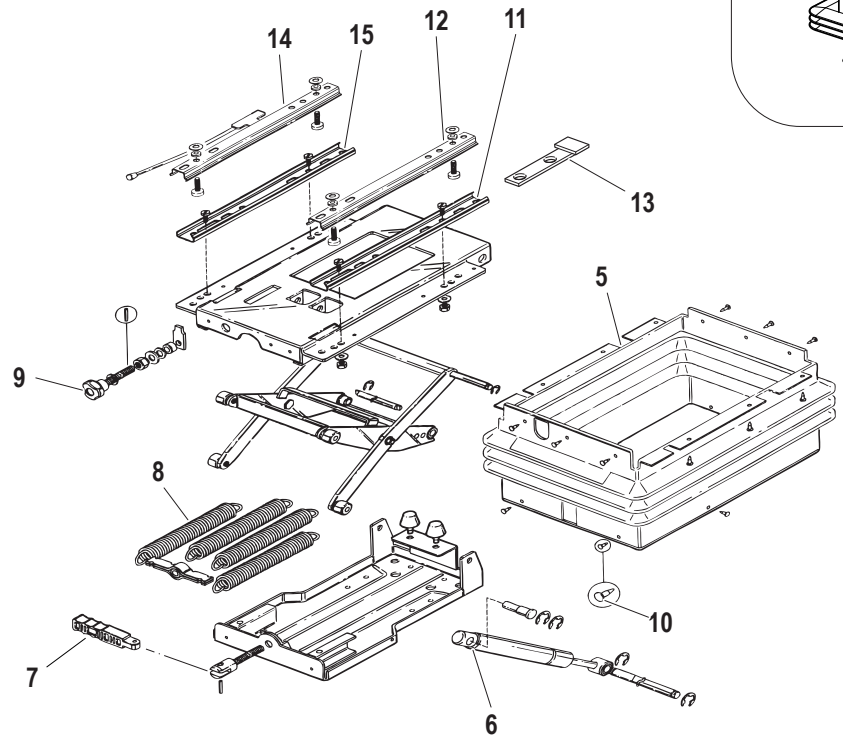
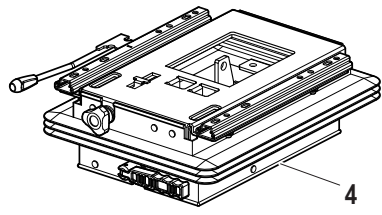
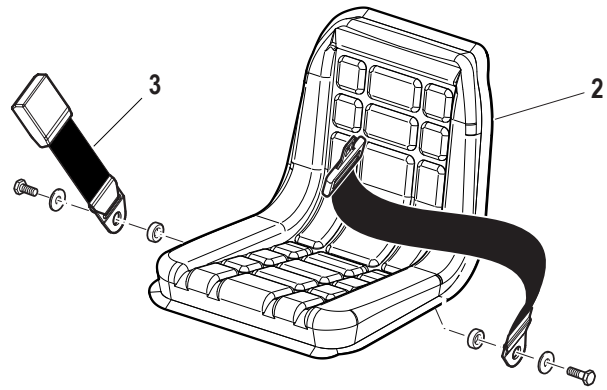

B.06.02-1

Pos.	Code	Q.ty	Description	Notes
1	58177722	1	SEAT	
2	59901050	1	SEAT	
3	58192377	1	SAFETY BELT	
4	59901049	1	SUSPENSION	
5	59900159	1	BELLOWS	
6	59900156	1	SHOCKS ABSORBER	
7	59900155	1	LEVER	
8	59900154	4	SPRING	
9	59900153	1	KNOB	
10	59900158	18	SCREW	
11	59900157	1	LOWER GUIDE	
12	59900160	1	GUIDE	
13	59071241	1	STOP PLATE	
14	59900161	1	GUIDE	
15	59900152	1	LOWER GUIDE	

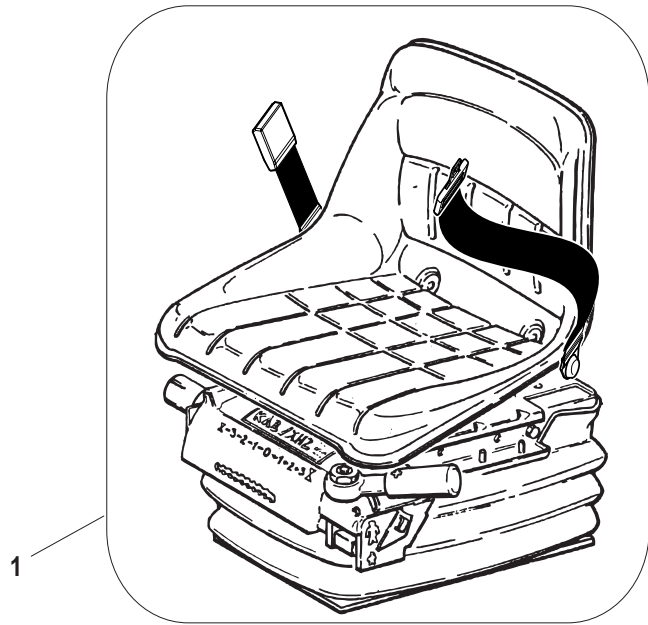

B.06.03-0

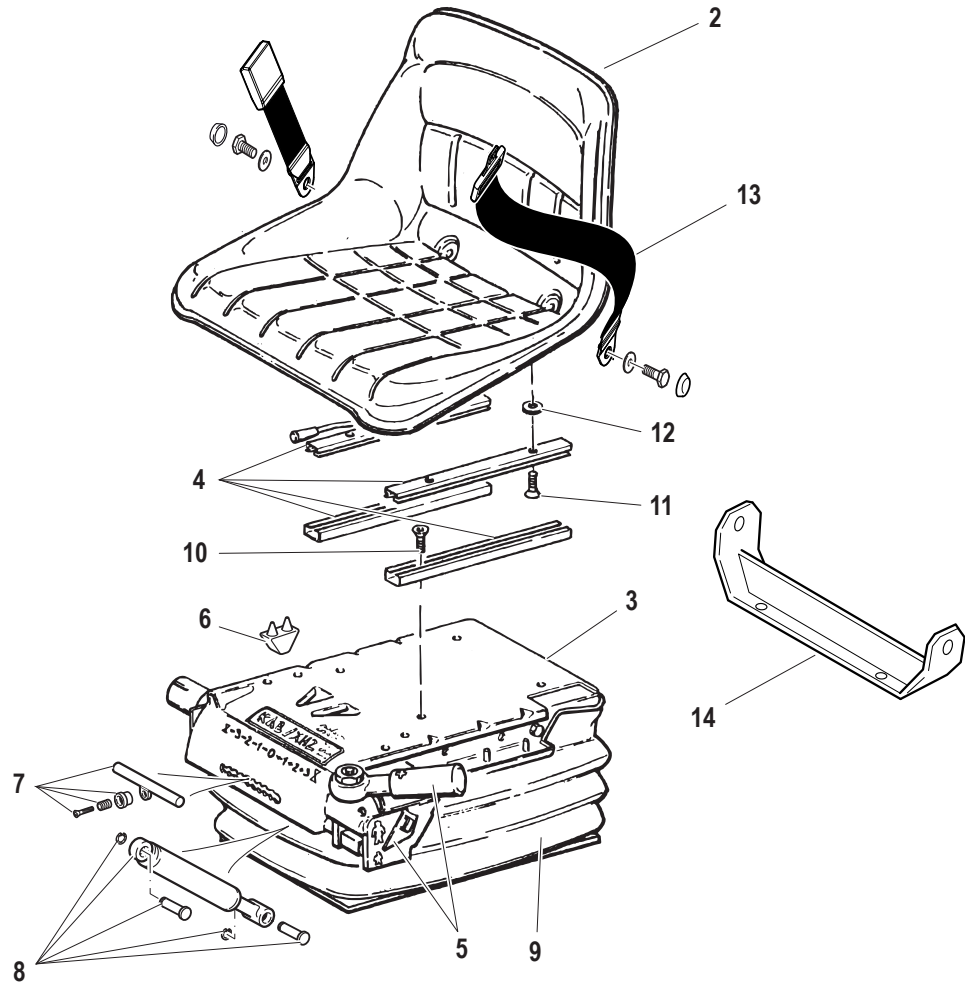

Pos.	Code	Q.ty	Description	Notes
1	59900199	1	SEAT	
2	F0150036216	1	SEAT CAVITY	
3	F0150036219	1	SPRING	
4	58173437	1	SEAT GUIDE	
5	59900183	1	CONTROL	
6	59900184	1	SPRINGS LIMITER	
7	59900185	1	CONTROL	
8	59900186	1	SHOCKS ABSORBER	
9	59900187	1	BELLOWS	
10	31111151	5	SCREW TE M8X16 UNI 5739 8G	
11	F0862495010	4	SCREW M8X16 UNI 5931	
12	F0843696000	6	WASHER D.24x8/6	
13	58192377	1	SAFETY BELT	
14	56178591	1	BRACKET	



ATTACCO SEDILE
SEAT CONNECTION
CONNEXION DU SIEGE
FAHRERSITZ-ANSCHLUSSTUTZEN
CONEXION ASIENTO

Tavola	Rev.	Data
B.07.01	1	04/2002

1/1

RS	AR
•	•

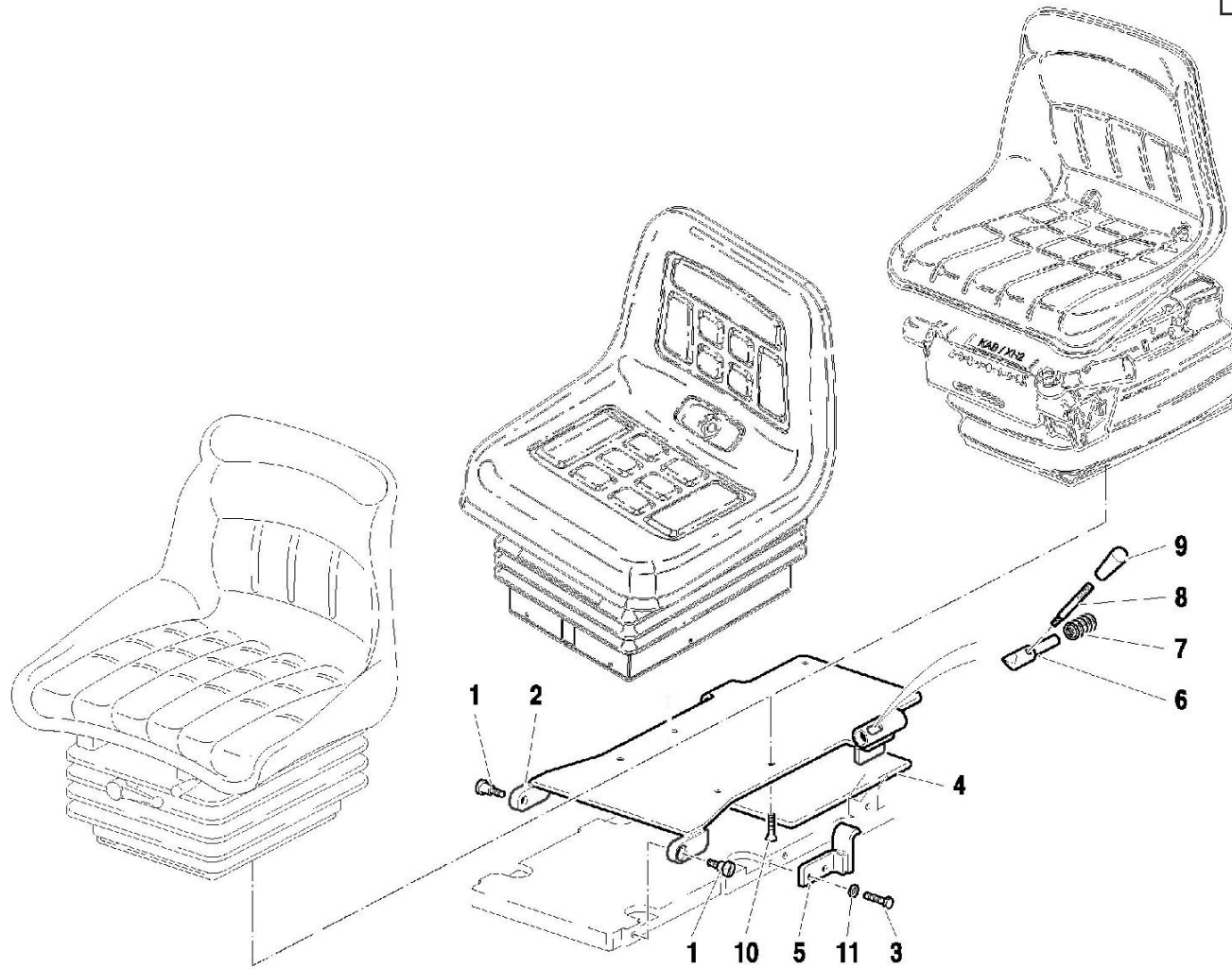

FERRARI

Pos.	Code	Q.ty	Description	Notes
1	F0010001078	0	PIN	
2	59071743	0	PLATE	
3	31112090	0	SCREW TE M6X16 UNI 5739 8G	
4	57370321	0	RUBBER	
5	59071745	0	BRACKET	
6	56371222	0	LOCKING BOLT	
7	58070390	0	SEAT SPRINGS	
8	56171237	0	HINGE PIN	
9	F0837521000	0	GRIP	
10	F0862481000	0	SCREW M8x16 UNI 5933	
11	F0843570000	0	WASHER 6	

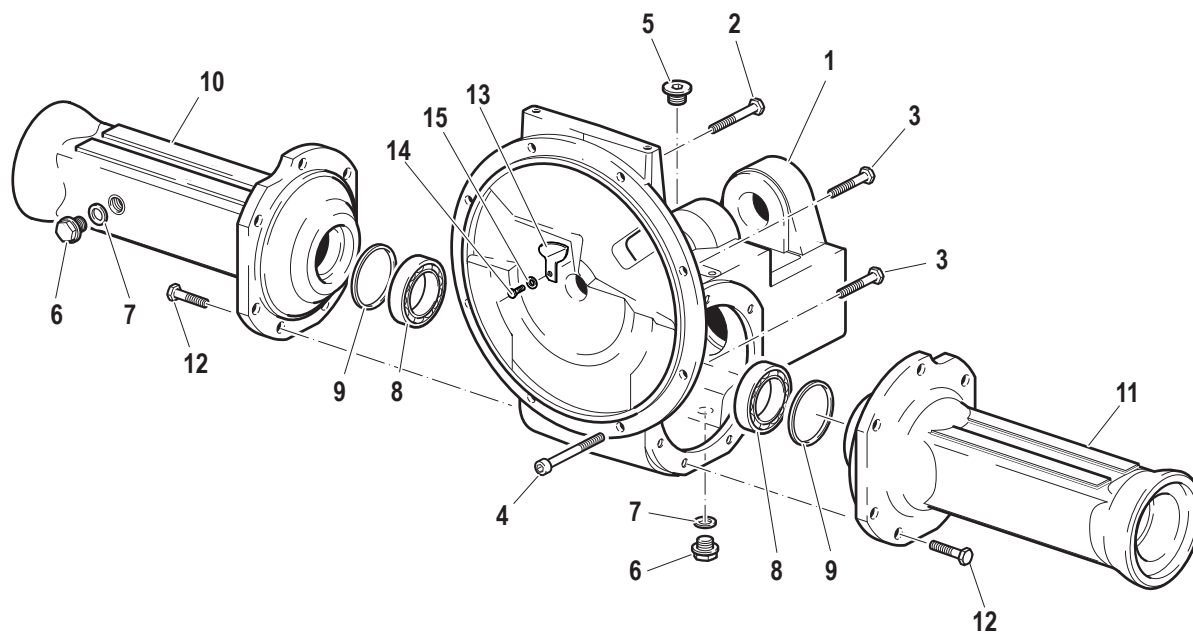

Pos.	Code	Q.ty	Description	Notes
1	51172967	0	FRONT AXLE HOUSING	
2	31112214	0	SCREW TE M10X45 UNI 5739	
3	31112211	0	SCREW TE M10X30 UNI 5739	
4	31152101	0	SCREW TCEI M10X45 UNI 5931 8G	
5	58071790	0	PLUG	
6	56370081	0	PLUG	
7	F0844273090	0	GASKET 22X28X1,5 CU 99,5	
8	F0812895000	0	BEARING 32008 (40X68X19)	
9	56371582	0	RING	
9	56371583	0	RING	
9	56371584	0	RING	
9	56371585	0	RING	
9	56371586	0	RING	
10	51273378	0	FRONT AXLE HOUSING	
11	51273377	0	FRONT AXLE HOUSING	
12	31112264	0	SCREW TE M12X35 UNI 5739	
13	56179398	1	COVER	
14	31111090	1	SCREW TE M5X10 UNI 5739 8G	
15	F0843570000	1	WASHER 6	

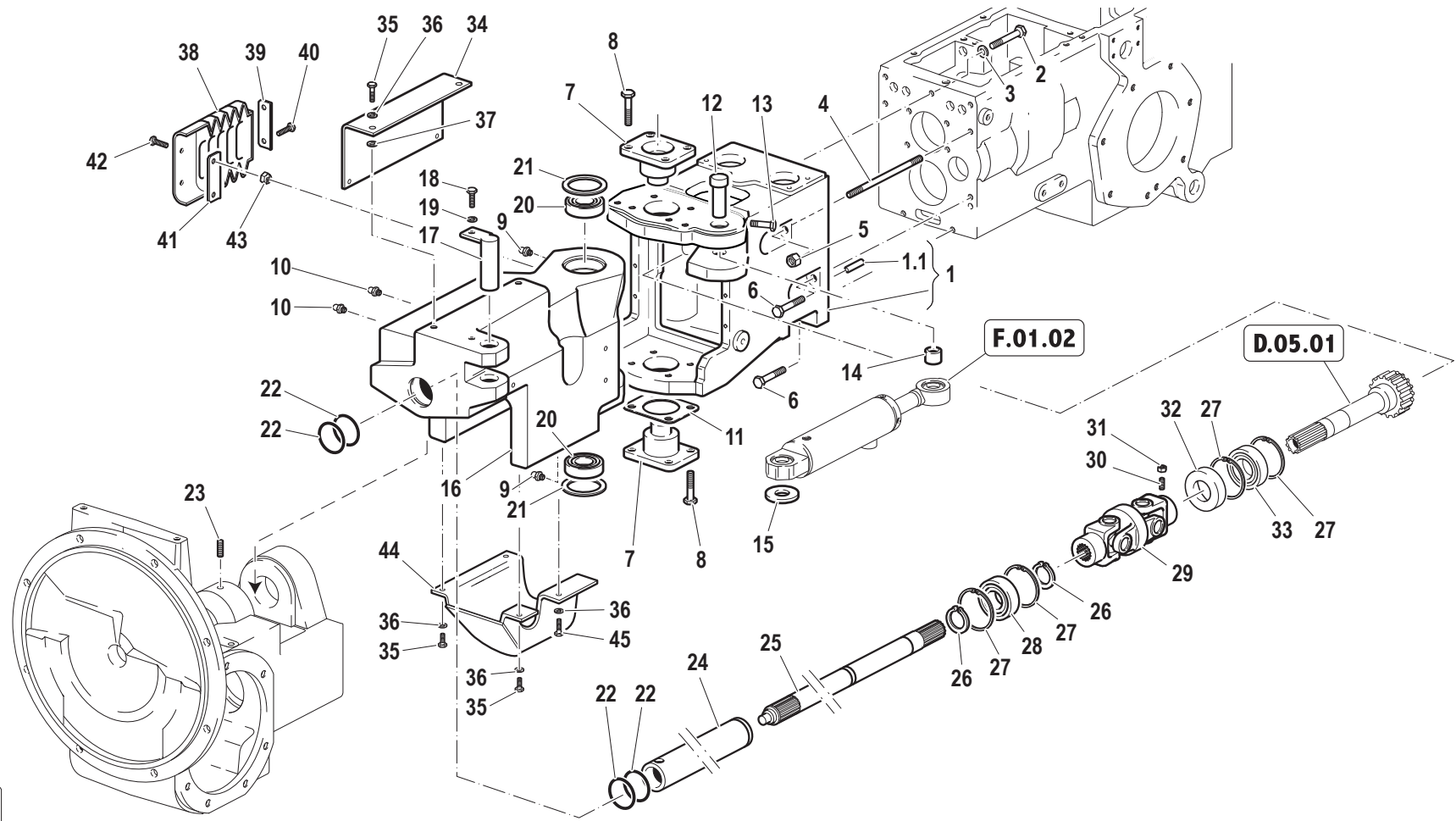

Pos.	Code	Q.ty	Description	Notes
1	59275173	1	BOX	
1.1	56370228	2	CYLINDRICAL PLUG	
2	F0863359000	1	SCREW M10X40 UNI 5737	
3	F0843755000	1	WASHER 10	
4	F0838530150	2	STUD BOLT M10X115 UNI 5911 8.8	
5	F0814647000	2	NUT M10	
6	31112211	4	SCREW TE M10X30 UNI 5739	
7	52379809	2	JOINT PIN	
8	F0863267050	8	SCREW M10x25	
9	30000007	2	LUBRICATOR	
10	F0826056000	2	LUBRICATOR M10 UNI 7663A	
11	52172158	1	SHIM	
11	52172159	1	SHIM	
11	52172160	1	SHIM	
11	52172161	1	SHIM	
11	52172162	1	SHIM	
12	56373542	1	HINGE PIN	
13	56370178	1	SCREW	
14	56170226	1	SPACER	
15	56173884	2	SPACER	
16	51179815	1	BOX	
17	59071171	1	HINGE PIN	
18	31111151	1	SCREW TE M8X16 UNI 5739 8G	
19	F0843643060	1	WASHER 8	
20	F0812747000	2	BEARING 32006X (30x55x17)	
21	58170077	2	GASKET	
22	38104412	4	O-RING 3175 (44,12X2,62)	
23	58170013	1	SCREW	
24	56471645	1	PIN	
25	52473449	1	FRONT CLUTCH SHAFT	
26	35121025	2	SEEGER RING E 25 DIN 471	
27	35111052	4	SEEGER RING I 52 DIN 472	
28	37112249	1	BEARING	
29	58170803	1	CARDAN JOINT	

SERIAL

INTERMEDIATE SECTION

CODE REV

C0202_2_48288

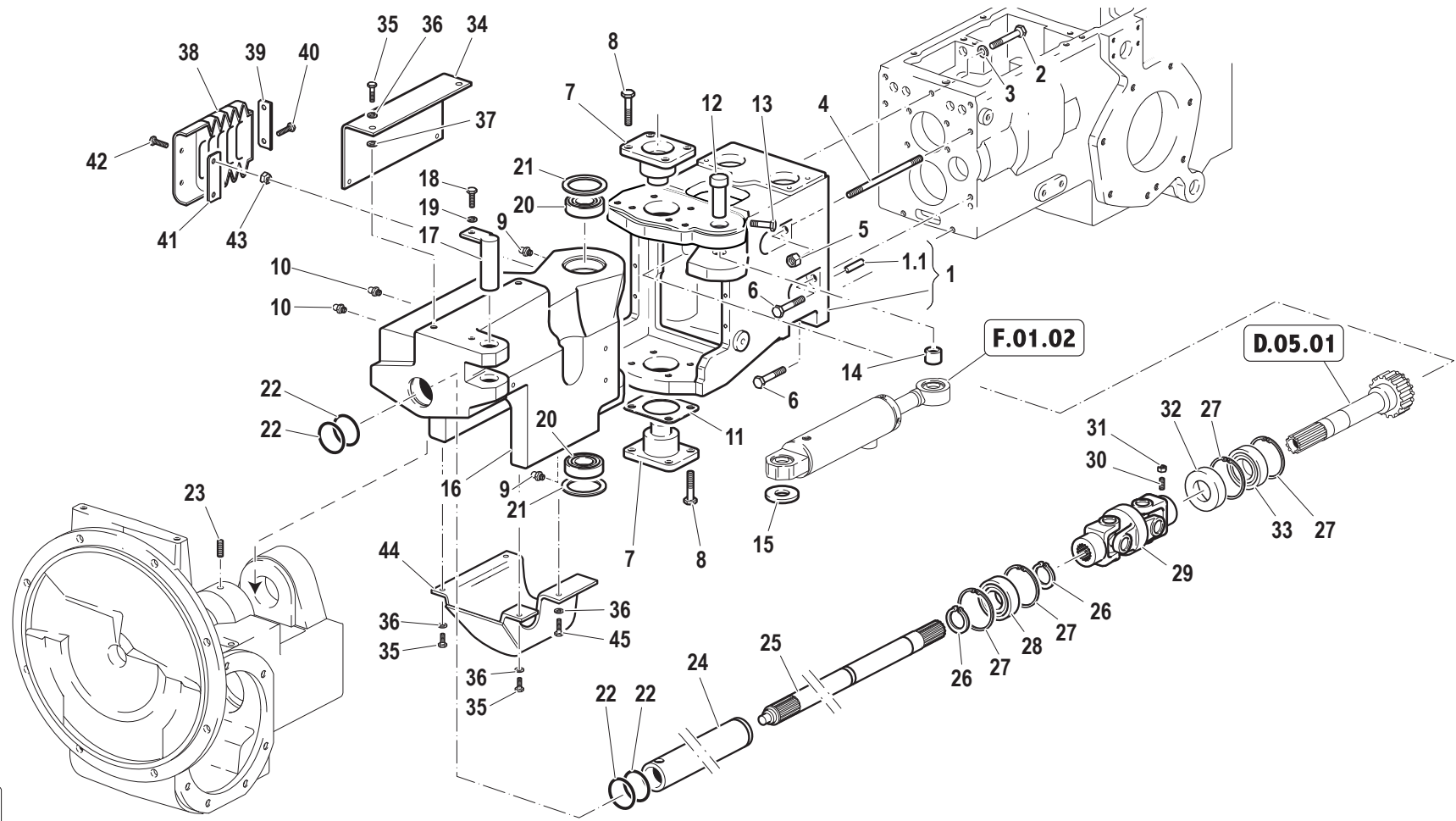

Pos.	Code	Q.ty	Description	Notes
30	F0862593050	1	SCREW M8X20 UNI 5927	
31	F0814574000	1	NUT M8	
32	F0802100050	1	SEAL 25x52/7	
33	37111255	1	BEARING	
34	59073500	1	SHIELD	
35	31112082	7	SCREW TE M6X12 UNI 5739 8G	
36	F0843570000	8	WASHER 6	
37	F0843578010	1	WASHER 6,4x11/1,6	
38	55172608	2	BELLOWS	
39	56173447	2	FIXING BRACKET	
40	31132562	4	SCREW TSVEI M6X16 UNI 5933	
41	56172163	2	FIXING BRACKET	
42	F0862210000	4	SCREW M6X25 UNI 5737	
43	F0814547000	4	SELFLOCK NUT M6	
44	56173497	1	SHIELD	
45	31112090	1	SCREW TE M6X16 UNI 5739 8G	

RS	AR
•	•

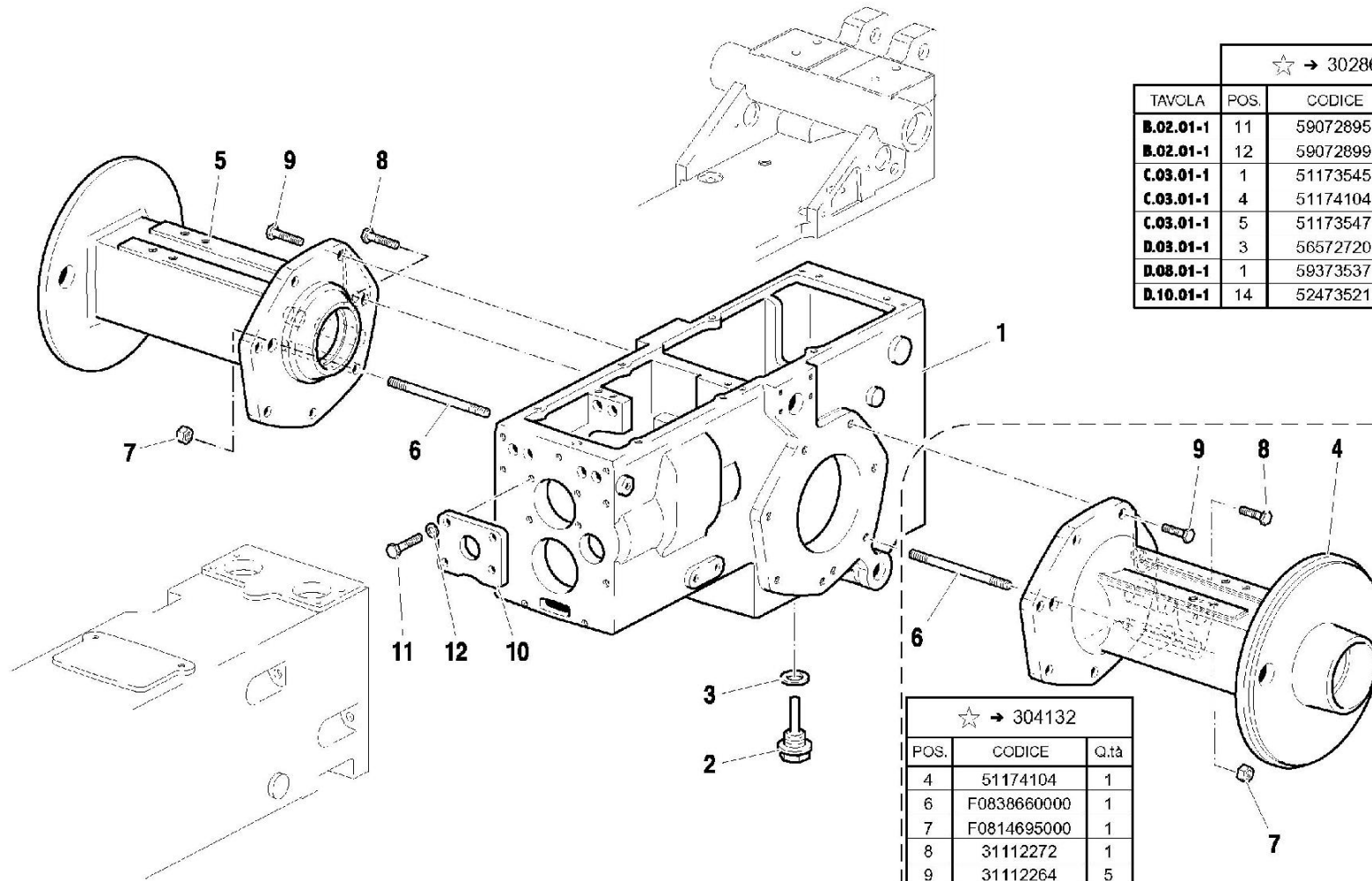

Pos.	Code	Q.ty	Description	Notes
1	51173545	0	GEAR BOX	
2	58170021	0	PLUG	
3	F0844273090	0	GASKET 22X28X1,5 CU 99,5	
4	51174104	0	REAR AXLE HOUSING	
5	51173547	0	REAR AXLE HOUSING	
6	F0838660000	0	STUD BOLT M12X105 UNI 5911-66	
7	F0814695000	0	NUT M12	
8	31112272	0	SCREW TE M12X30 UNI 5739	
9	31112264	0	SCREW TE M12X35 UNI 5739	
10	56172685	0	FRONT COVER	
11	31112219	0	SCREW TE M10X25 UNI 5739	
12	F0843755000	0	WASHER 10	

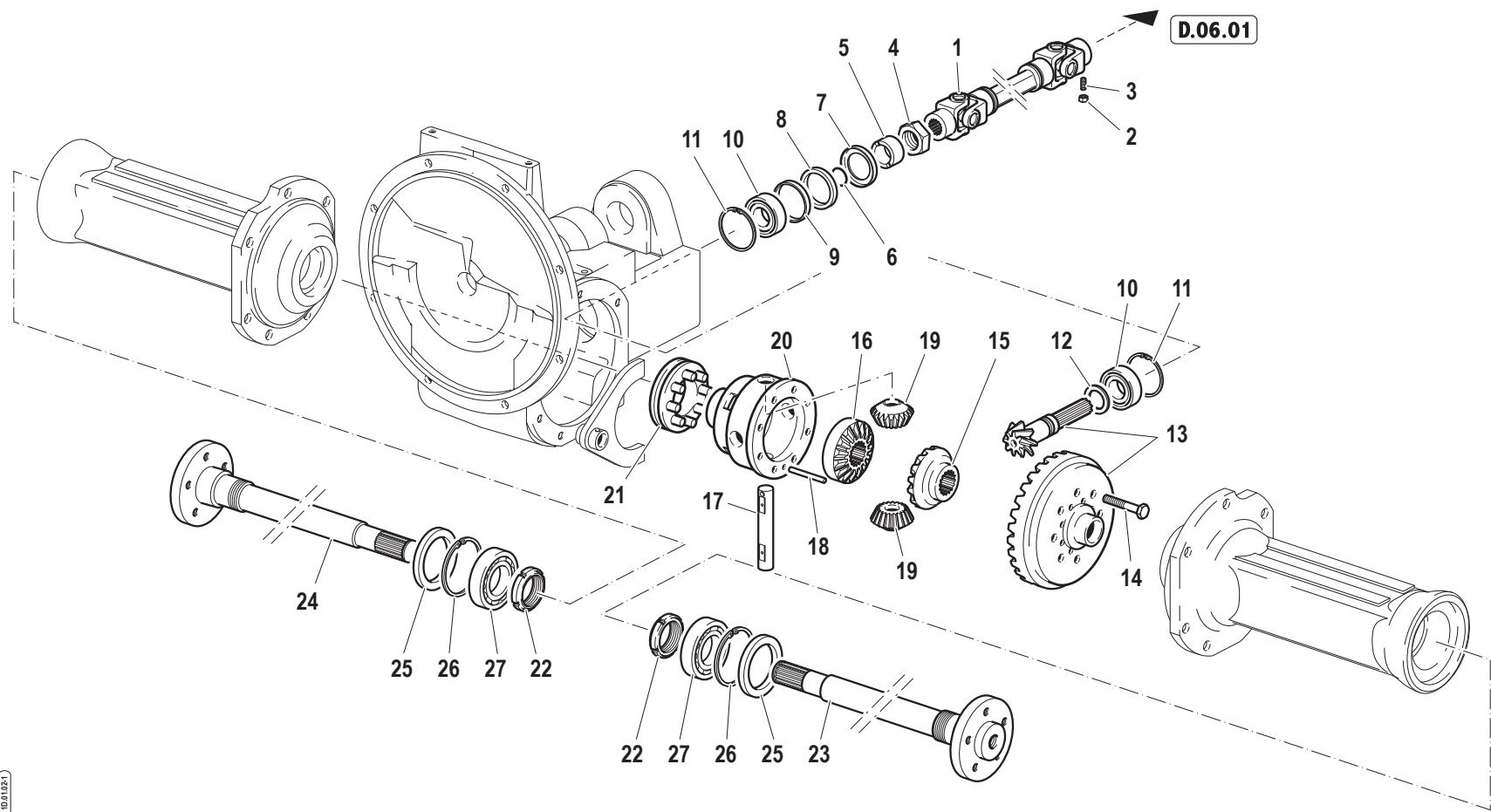

Pos.	Code	Q.ty	Description	Notes
1	58179168	1	CONSTANT VEL. JOINT	
2	F0814574000	0	NUT M8	
3	F0862657000	0	GRAIN	
4	56371666	0	RING NUT	
5	56471665	0	SPACER	
6	38112670	0	O-RING	
7	56171671	0	PROTECTIVE RING D=62	
8	F0802190010	0	SEAL 42x62/7	
9	56171672	0	SPACER	
10	37221300	0	CYL. ROLLER BEARING	
11	35111063	0	SEEGER RING I 62 UNI 7438	
12	56371667	0	SHIM	
12	56371668	0	SHIM	
12	56371669	0	SHIM	
12	56371670	0	SHIM	
13	59372713	0	BEVEL GEAR	
14	F0863267050	0	SCREW M10x25	
15	52471513	0	CROWN WHEEL	
16	52471516	0	CROWN WHEEL	
17	56471508	0	PIN	
18	56371994	0	PIN	
19	52471509	0	PLANETARY GEAR	
20	51374866	0	HOUSING	
21	59071518	0	SLEEVE	
22	F0821057000	0	SELFLOCK.RING NUT M40x1,5/D=5	
23	52477270	1	AXLE SHAFT	
24	52477271	1	AXLE SHAFT	
25	F0802239052	0	SEAL 50X80X8	
26	35111080	0	SEEGER RING I 80 DIN 472	
27	37111404	0	BEARING	

SERIAL

FRONT TRANSMISSION

CODE REV

D0102_1_19161

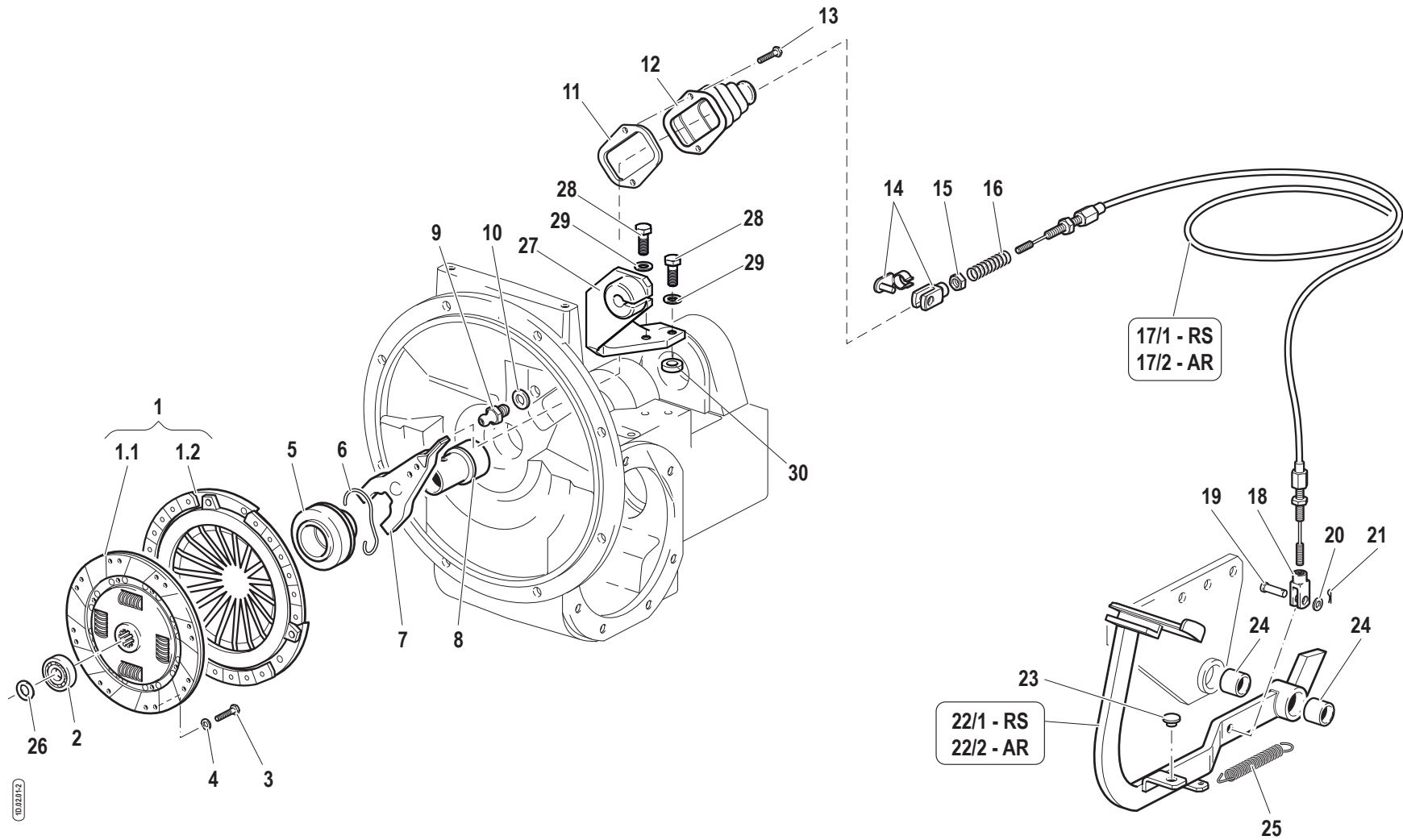

Pos.	Code	Q.ty	Description	Notes
1	58172957	1	CLUTCH ASSY	
1.1	58172958	1	CLUTCH DISC	
1.2	59900226	1	CLUTCH THRUST PLATE	
2	F0812523050	1	BEARING 6201-2RS	
3	31111091	1	SCREW E M6X14 UNI 5739 8G	
4	F0843570000	1	WASHER 6	
5	F0819134030	1	SLEEVE	
6	F0819134050	1	RETAINING SPRING	
7	58072688	1	FORK	
8	56172643	1	SLEEVE	
9	F0819134040	1	PIN	
10	F0843755000	1	WASHER 10	
11	56074020	1	CLAMPING PLATE	
12	55174021	1	BOOT	
13	31112090	1	SCREW TE M6X16 UNI 5739 8G	
14	F0860058000	1	COMPLETE FORK	
15	F0814627000	1	NUT M10	
16	F0831193010	1	SPRING DM.15X70	
17/1	58176971	1	CABLE	
17/2	58176970	1	CABLE	
18	50974039	1	FORK	
19	56470365	1	PIN	
20	31411105	1	WASHER 10,5x21	
21	F0810510000	1	SPLIT PIN A2,0X20 UNI 1336	
22/1	59073604	1	CLUTCH PEDAL	
22/2	59073514	1	CLUTCH PEDAL	
23	F0822537050	1	BUFFER	
24	58171596	1	BUSHING	
25	F0831139000	1	SPRING	
26	56179424	1	THRUST PLATE	
27	59079661	1	FIXING BRACKET	
28	31112151	1	SCREW TE M8X25 UNI 5739 8G	
29	F0843643060	1	WASHER 8	
30	F0843696000	1	WASHER D.24x8/6	

SERIAL

CLUTCH

CODE REV

D0201_2_48405



FRENI
BRAKES
FREINS
BREMSEN
FRENOS

Tavola	Rev.	Data
D.03.01	1	04/2002

1/1

RS	AR
•	•

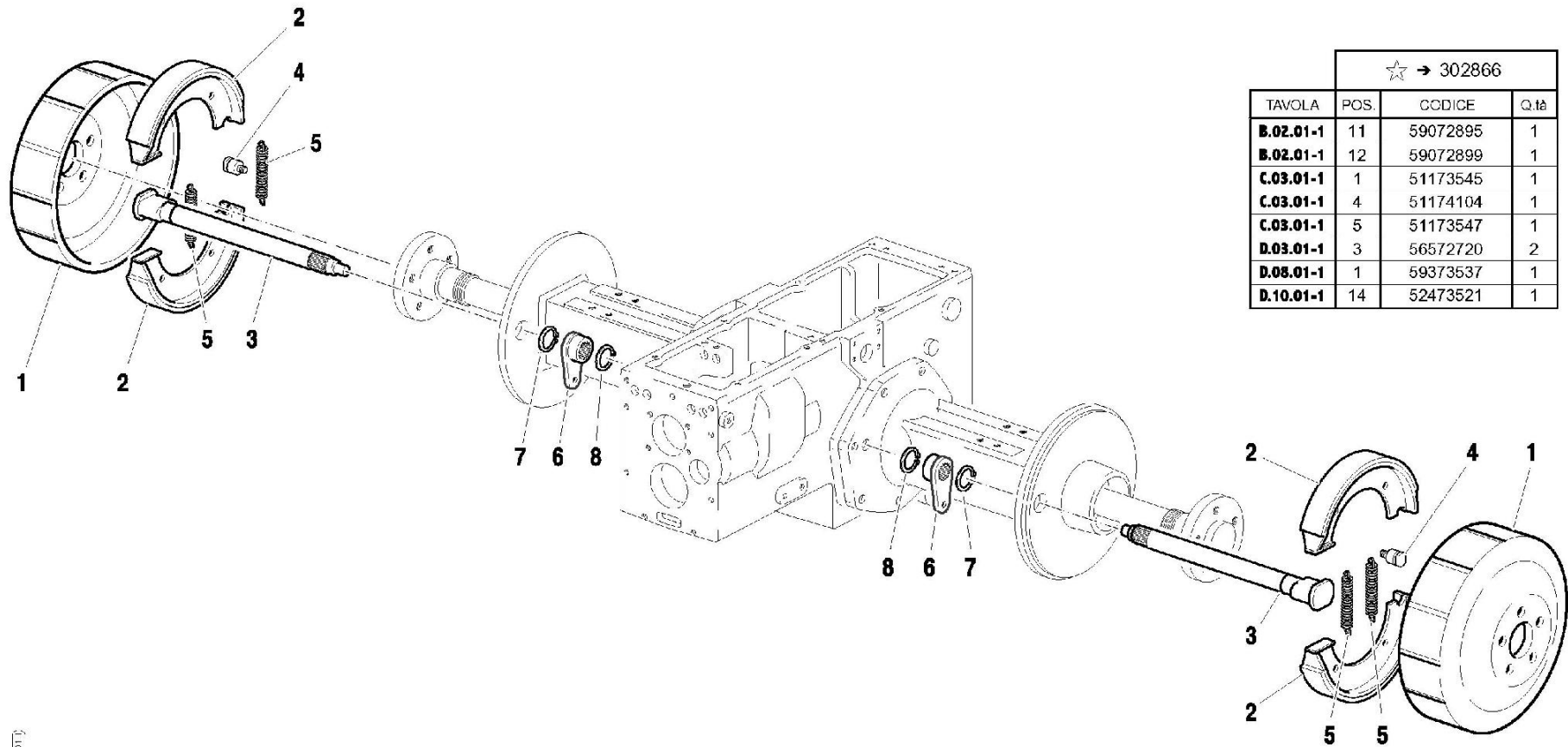

☆ → 302866			
TAVOLA	POS.	CODICE	Q.tà
B.02.01-1	11	59072895	1
B.02.01-1	12	59072899	1
C.03.01-1	1	51173545	1
C.03.01-1	4	51174104	1
C.03.01-1	5	51173547	1
D.03.01-1	3	56572720	2
D.08.01-1	1	59373537	1
D.10.01-1	14	52473521	1

Pos.	Code	Q.ty	Description	Notes
1	51172716	0	BRAKE DRUM	
2	58172717	0	BRAKE BLOCK	
3	56572720	0	SHAFT	
4	56172719	0	PIN	
5	58172718	0	SPRING	
6	52373346	0	LEVER	
7	35121028	0	SEEGER RING E 28 DIN 471	
8	F0801190000	0	SEEGER RING E 26 UNI 7435	

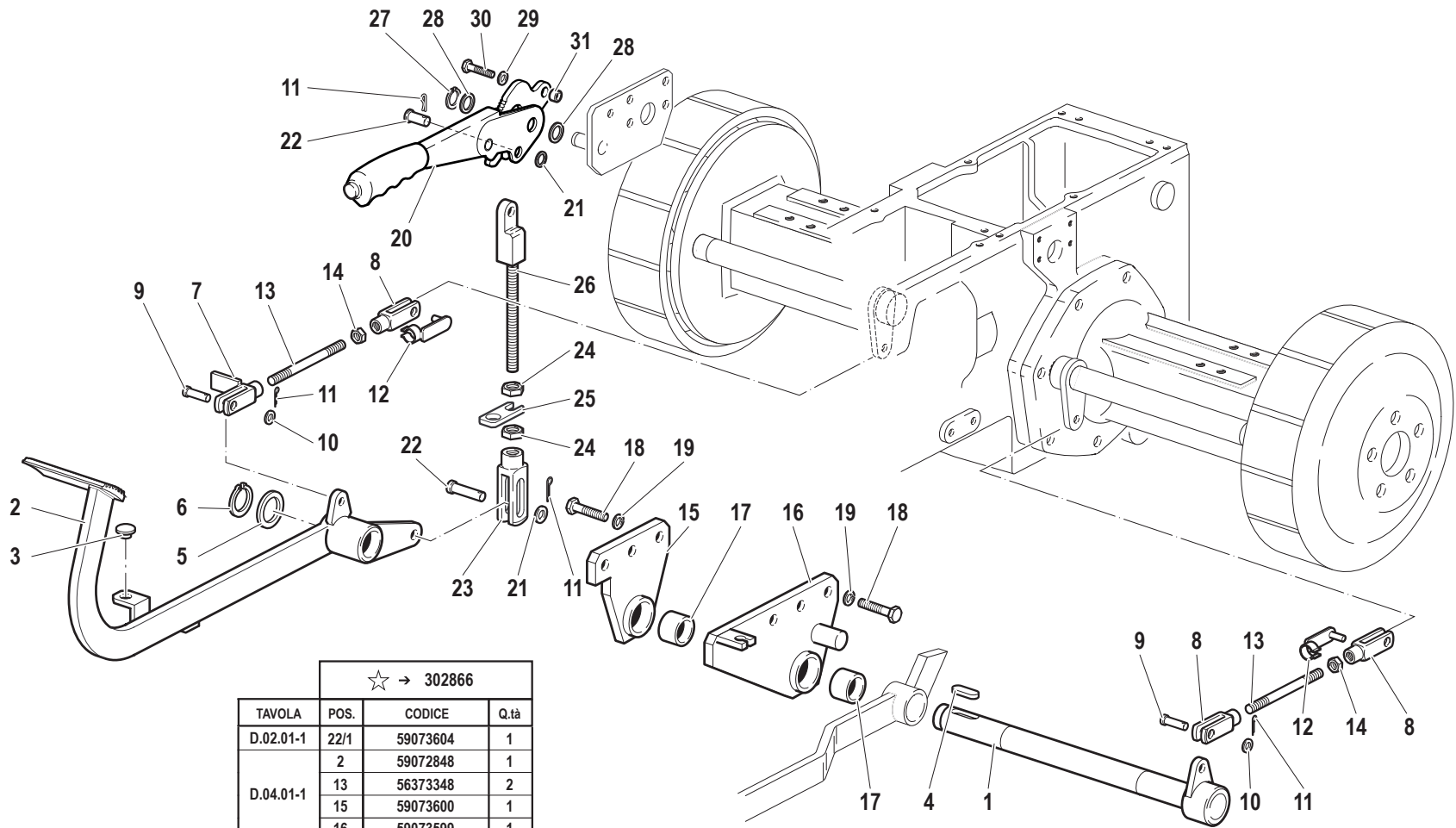

Pos.	Code	Q.ty	Description	Notes
1	59072859	1	SHAFT	
2	59072848	1	BRAKE PEDAL	
3	F0822537050	1	BUFFER	
4	F0806533000	1	KEY 8X7X30 UNI 6604/A	
5	56349629	1	RING	
6	F0801185010	1	SEEGER RING E 25X2	
7	59072904	1	FORK	
8	F0860060010	1	FORK	
9	F0835523000	1	PIN	
10	31411084	1	WASHER 8,4x17	
11	F0810510000	1	SPLIT PIN A2,0X20 UNI 1336	
12	F0860060020	1	PIN	
13	56373348	1	ROD	
14	F0814569000	1	NUT M8 UNI 5589 CL:8	
15	59073600	1	SUPPORT	
16	59073599	1	SUPPORT	
17	58171596	1	BUSHING	
18	F0863217060	1	SCREW M10X22 UNI 5739	
19	F0843755000	1	WASHER 10	
20	58178960	1	HANDBRAKE LEVER	
21	31411105	1	WASHER 10,5x21	
22	56470365	1	PIN	
23	50972173	1	FORK	
24	F0814627000	1	NUT M10	
25	56073094	1	SMALL PLATE	
26	59073093	1	HANDBRAKE TIE-ROD	
27	F0801095000	1	SEEGER RING E 14 7435	
28	31411150	1	WASHER 15x28	
29	F0843643060	1	WASHER 8	
30	31112151	1	SCREW TE M8X25 UNI 5739 8G	
31	56171936	1	SPACER	



ALBERO PRIMARIO E RELATIVI INGRANAGGI
MAIN SHAFT AND CORRESPONDING GEARS
ARBRE PRIMAIRE ET ENGRENAGES RELATIFS
HAUPTWELLE UND ENTSPRECHENDE ZÄHNRÄDER
ARBOL PRIMARIO Y RESPECTIVOS ENGRANAJES

Tavola	Rev.	Data
D.05.01	1	04/2002

1/1

RS	AR
•	•

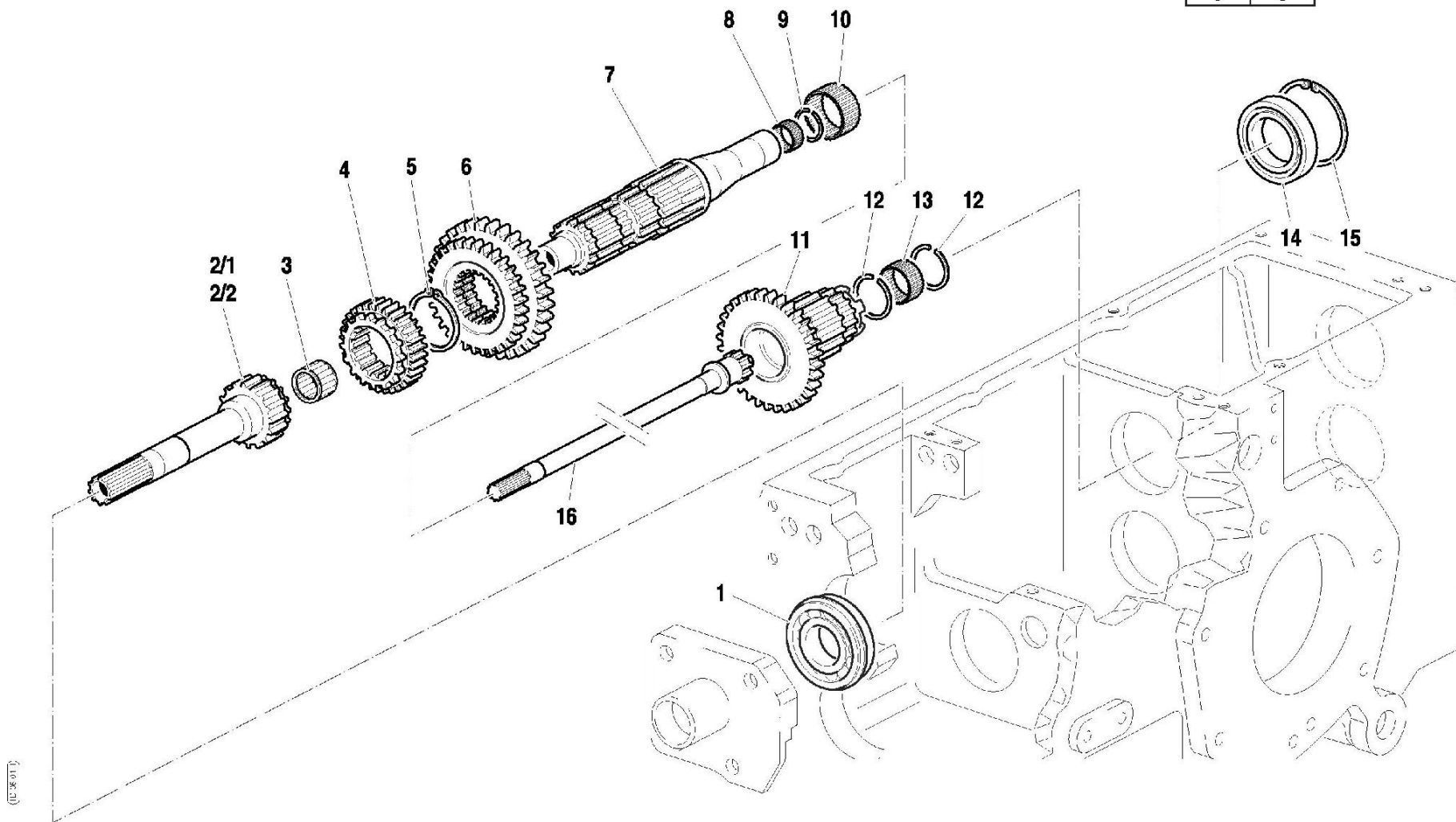

(12-2002)

Pos.	Code	Q.ty	Description	Notes
1	F0812849100	0	BEARING 6207-NR	
2/1	59372819	0	SHAFT	
2/2	59373451	0	SHAFT	
3	F0812689000	0	ROLLER CAGE K 25X30/20 H	
4	52472646	0	SLIDING GEAR	
5	F0801331000	0	SEEGER RING E 45 UNI 7435	
6	52472651	0	SLIDING GEAR	
7	52472654	0	OUTPUT SHAFT	
8	37320155	0	ROLLER CAGE 16X20/13	
9	F0801151000	0	SAFETY RING	
10	F0812871030	0	ROLLER CAGE K 37X42/17	
11	52476788	1	GEAR	
12	F0801248000	0	SAFETY RING	
13	F0812733075	0	ROLLER CAGE K 28X33/17	
14	F0812933000	0	BEARING 6009	
15	F0801425000	0	SEEGER RING I 75 UNI 7437	
16	52472659	0	SHAFT	



INGRANAGGI ALBERO SECONDARIO
TRANSMISSION SHAFT GEARS
ENGRENAGES ARBRE SECONDAIRE
VORGELEGEWELLENZÄHRÄDER
ENGRANAJES DEL ARBOL SECUNDARIO

Tavola	Rev.	Data
D.06.01	1	04/2002

1/1

RS	AR
•	•

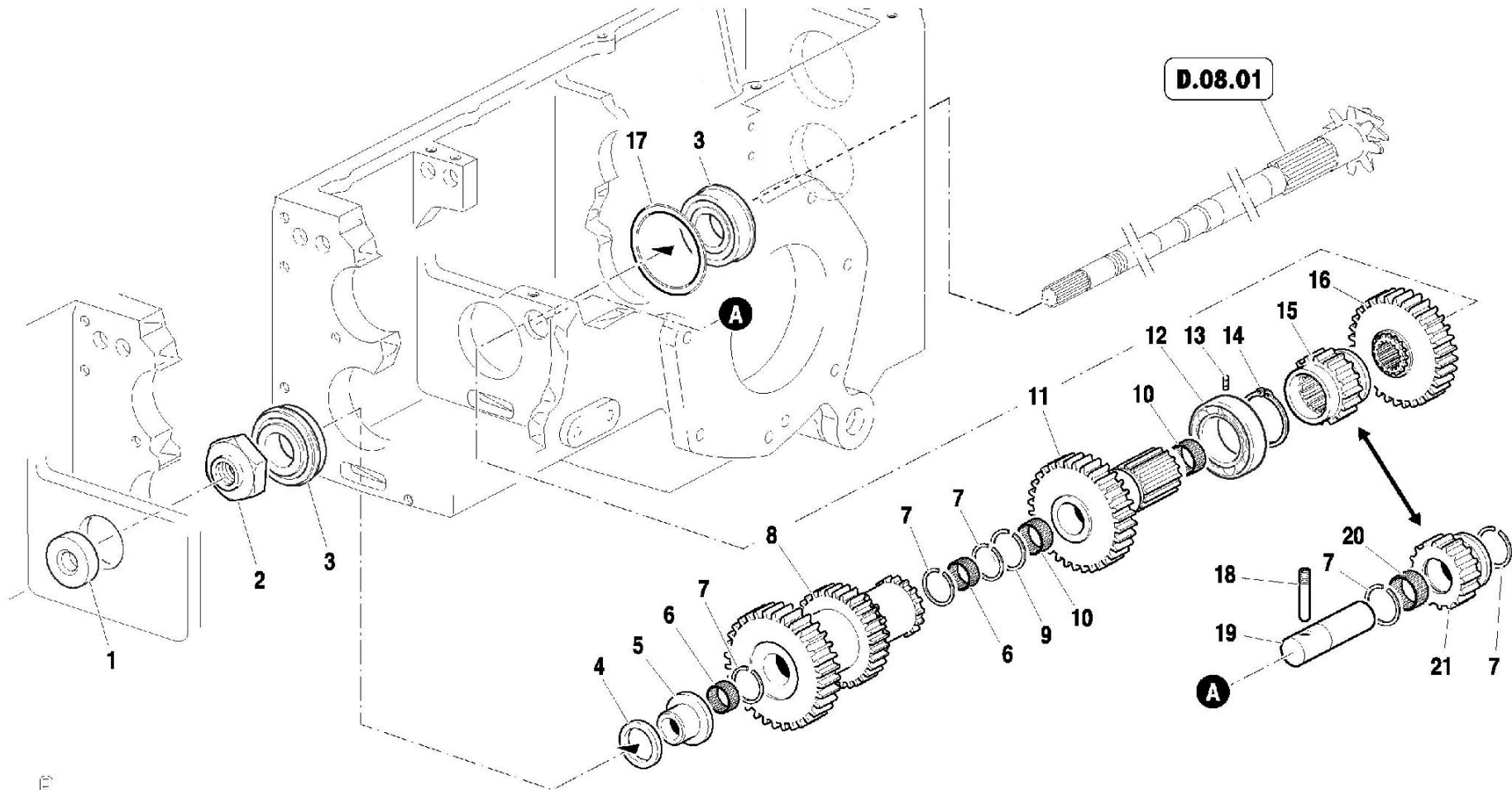

11111111

Pos.	Code	Q.ty	Description	Notes
1	38212003	0	OIL SEAL 20x42/7	
2	56371652	0	NUT	
3	F0812810100	0	BEARING	
4	56371656	0	ADJUSTING RING	
4	56371657	0	ADJUSTING RING	
4	56371658	0	ADJUSTING RING	
4	56371659	0	ADJUSTING RING	
4	56371660	0	ADJUSTING RING	
5	56471655	0	BUSHING	
6	F0812689000	0	ROLLER CAGE K 25X30/20 H	
7	F0801241005	0	SAFETY RING	
8	52472928	0	GEAR	
9	F0801248000	0	SAFETY RING	
10	F0812733075	0	ROLLER CAGE K 28X33/17	
11	52475450	1	GEAR	
12	50973529	0	ROLLER BEARING	
13	F0862037050	0	GRAIN	
14	F0801331100	0	RETAINING RING AV45 M1408	
15	52476787	1	SLIDING SLEEVE	
16	52472657	0	DRIVEN GEAR	
17	56371661	0	ADJUSTING RING	
17	56371662	0	ADJUSTING RING	
17	56371663	0	ADJUSTING RING	
17	56371664	0	ADJUSTING RING	
17	56373440	0	ADJUSTING RING	
18	56370178	0	SCREW	
19	56376791	1	GEAR PIN	
20	F0812686100	0	ROLLER CAGE K 25X30X24 H	
21	52472852	0	INTERMEDIATE WHEEL	

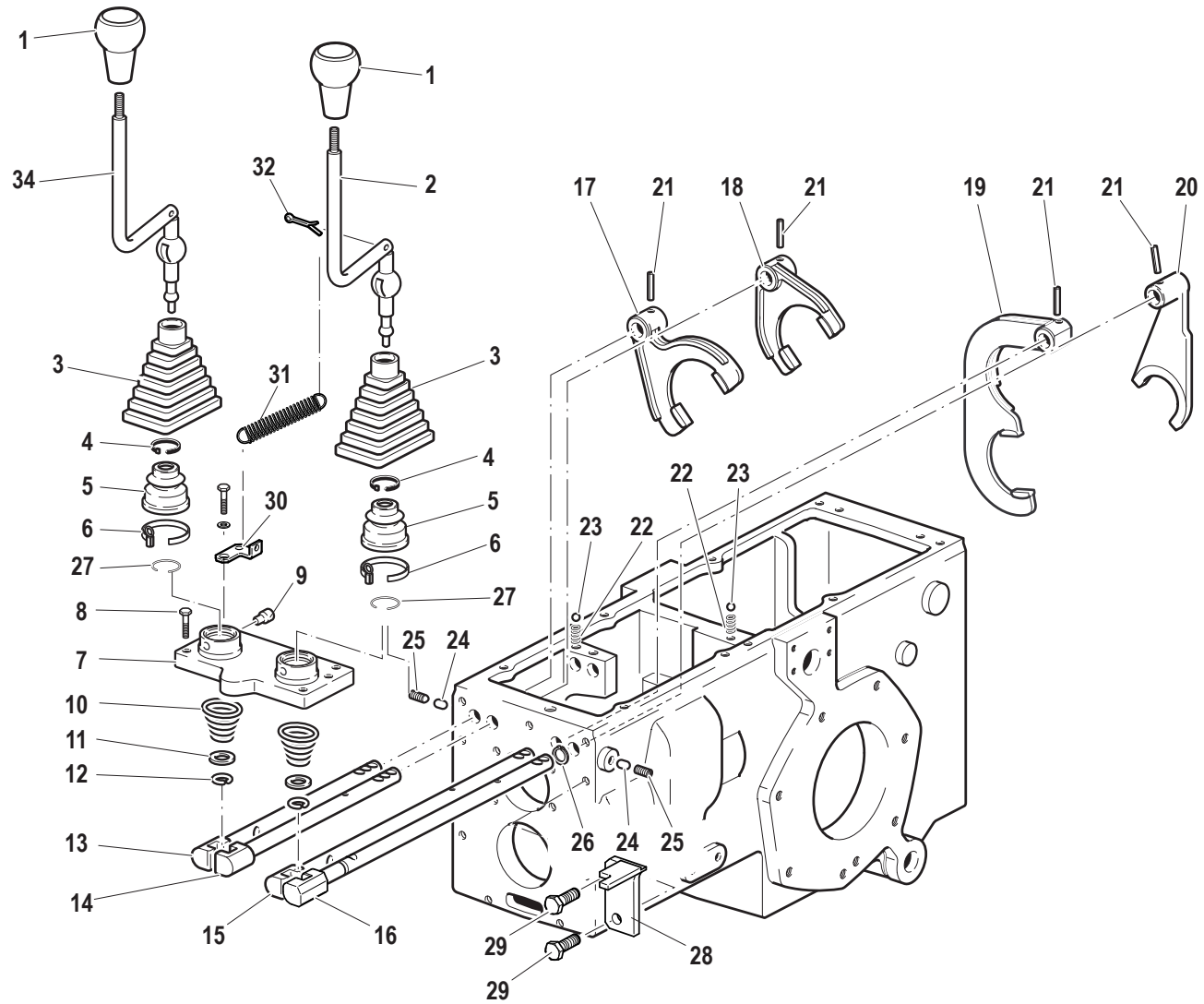

Pos.	Code	Q.ty	Description	Notes
1	58174192	2	HANDLE	
2	59076793	2	COMMAND LEVER	
3	55174163	2	BELLOWS	
4	58070169	1	LOCKRING	
5	55170053	2	CAP	
6	58170054	1	COLLAR	
7	51172684	1	COVER	
8	F0862694000	4	SCREW M8X170 UNI 5737	
9	56370018	4	HINGE PIN	
10	58070164	2	SPRING	
11	56370172	2	SPACER	
12	58070168	2	LOCKRING	
13	56372774	1	GEARSHIFT ROD	
14	56372775	1	GEARSHIFT ROD	
15	56372776	1	PULL ROD	
16	56376796	1	PULL ROD	
17	51272728	1	SELECTOR FORK	
18	51272729	1	SELECTOR FORK	
19	51272730	1	GEAR FORK	
20	59072731	1	FORK	
21	F0851180000	4	PIN 5X26 DIN 1481 CL:C72	
22	58070741	4	SPRING	
23	F0847434000	4	BALL	
24	56571697	2	TOGGLE	
25	F0863183000	2	SCREW M10X16 UNI 5923	
26	35121014	1	SEEGER RING E 14 DIN 471	
27	F0817640003	2	CLAMP 4,8x180	
28	59076794	1	STOP PLATE	
29	31112212	2	SCREW TE M10X35 UNI 5739	
30	56176795	1	BRACKET	
31	F0831139000	1	SPRING	
32	34110031	1	SPLIT PIN	
33	59978068	1	KIT	
34	59074187	1	COMMAND LEVER	

SERIAL

CHANGE GEAR CONTROLS

CODE REV

D0701_2_48498



TRASMISSIONE POSTERIORE
 REAR TRANSMISSION
 TRANSMISSION ARRIÈRE
 HINTERANTRIEB
 TRASMISION TRASERA

Tavola	Rev.	Data
D.08.01	1	04/2002

1/1

RS	AR
•	•



TAVOLA	POS.	CODICE	Q.tà
		☆ → 302866	
B.02.01-1	11	59072895	1
B.02.01-1	12	59072899	1
C.03.01-1	1	51173545	1
C.03.01-1	4	51174104	1
C.03.01-1	5	51173547	1
D.03.01-1	3	56572720	2
D.08.01-1	1	59373537	1
D.10.01-1	14	52473521	1

10/2002

Pos.	Code	Q.ty	Description	Notes
1	59373537	0	BEVEL GEAR	
2	F0863267050	0	SCREW M10x25	
3	52472701	0	CROWN WHEEL	
4	52472700	0	CROWN WHEEL	
5	52471509	0	PLANETARY GEAR	
6	56572694	0	SMALL BLOCK	
7	56371994	0	PIN	
8	56471508	0	PIN	
9	56472695	0	PIN	
10	51374867	0	HOUSING	
11	56472698	0	SLEEVE	
12	F0812895100	0	BEARING 32009X	
13	56372702	0	RING	
13	56372703	0	RING	
13	56372704	0	RING	
13	56372705	0	RING	
13	56372706	0	RING	
14	F0821057000	0	SELFLOCK.RING NUT M40x1,5/D=5	
15	37111404	0	BEARING	
16	35111080	0	SEEGER RING I 80 DIN 472	
17	F0802239052	0	SEAL 50X80X8	
18	52472711	0	REAR AXLE SHAFT	
19	52472712	0	REAR AXLE SHAFT	

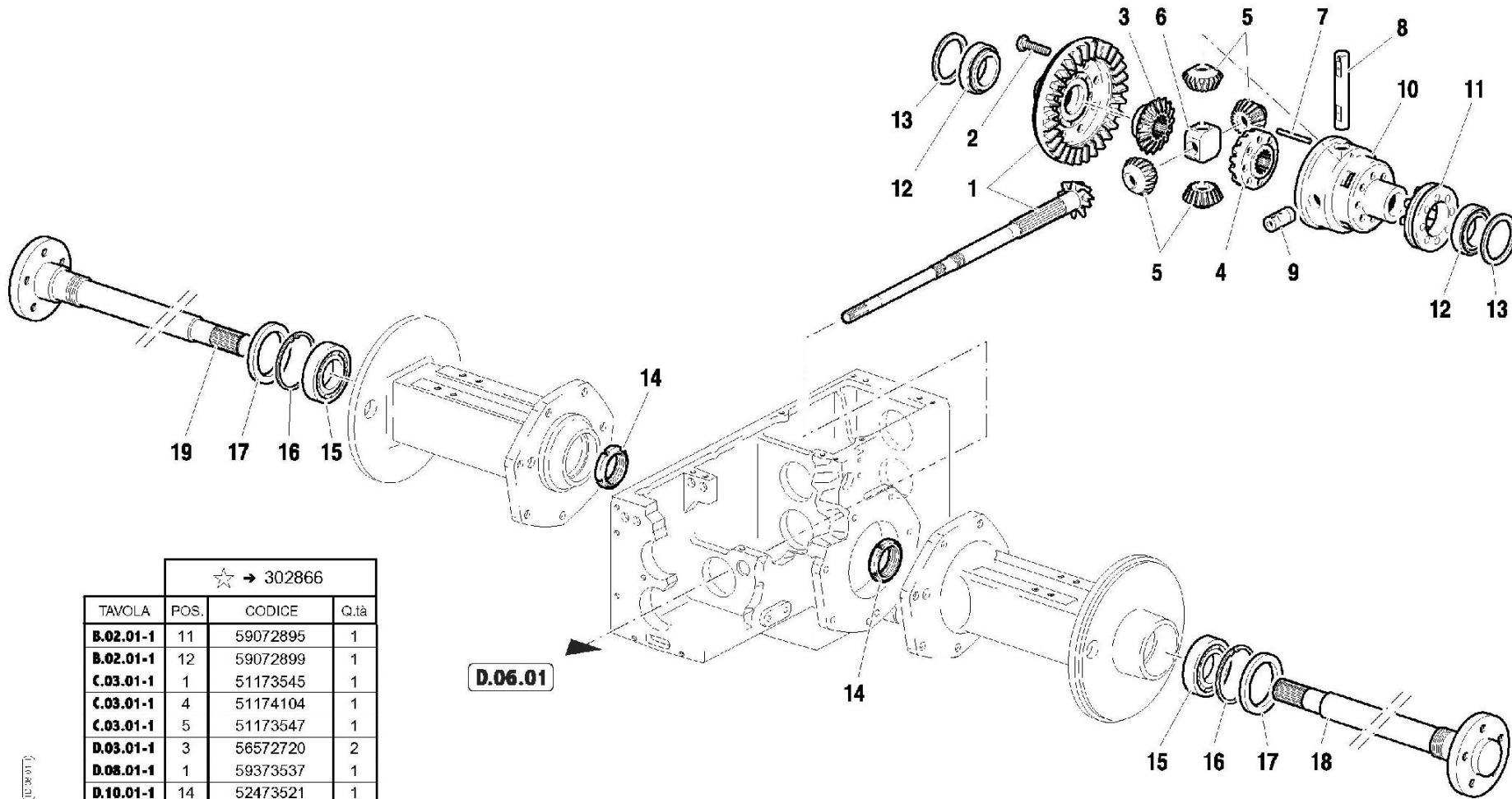

BLOCCAGGIO DIFFERENZIALE
DIFFERENTIAL GEAR LOCK
BLOCAGE DU DIFFERENTIEL
DIFFERENTIALSPERRE
BLOQUEO DEL DIFERENCIAL

Tavola	Rev.	Data
D.09.01	1	04/2002

1/1

RS	AR
•	•

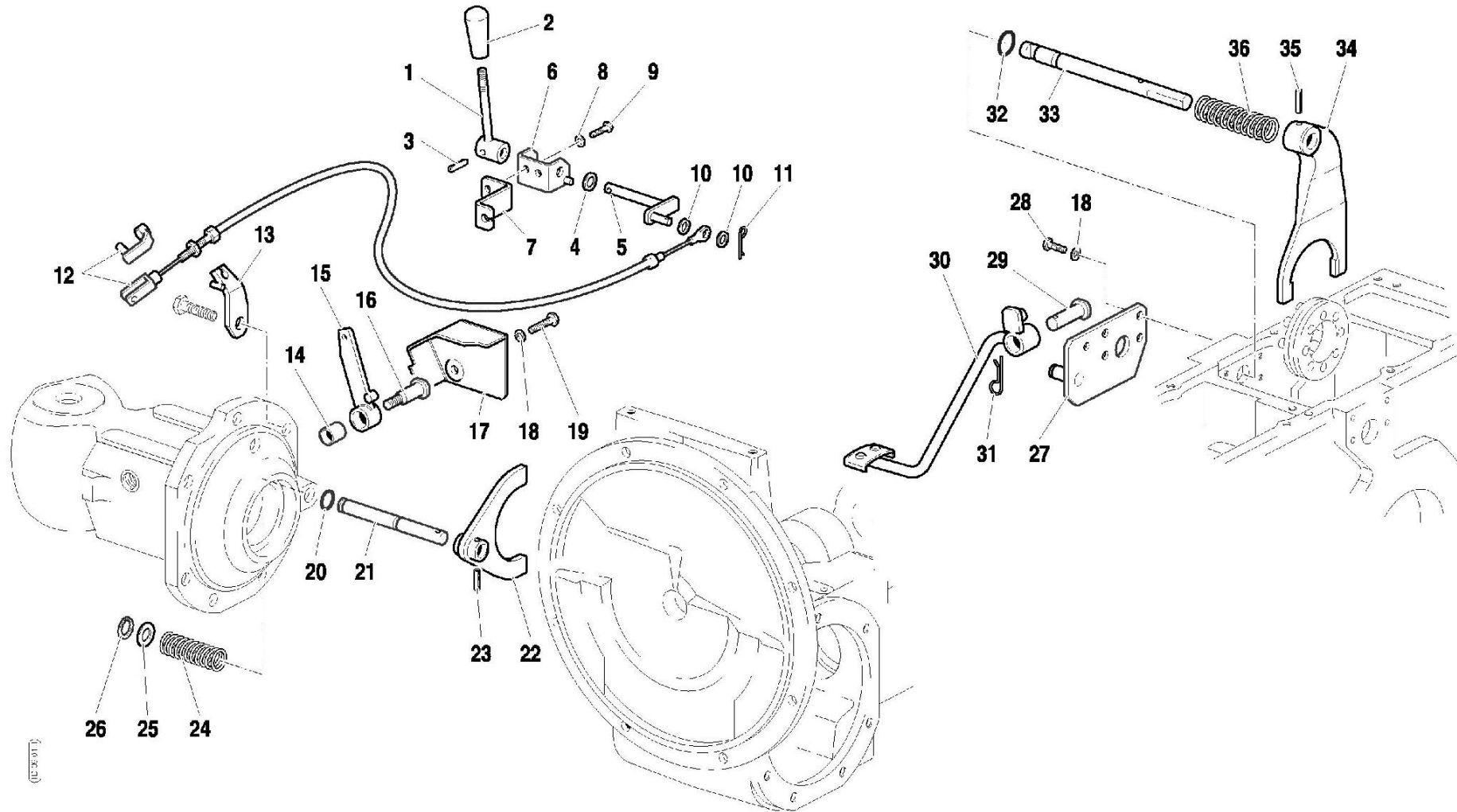

Pos.	Code	Q.ty	Description	Notes
1	59072008	0	LEVER	
2	P29533200000	0	GRIP	
3	34211030	0	ROLL PIN	
4	31411104	0	WASHER 10,5x18	
5	59072007	0	LOCKING BOLT	
6	59072006	0	BRACKET	
7	56172009	0	BRACKET	
8	F0843570000	0	WASHER 6	
9	31112093	0	SCREW TE M6X20 UNI 5739 8G	
10	31411064	0	WASHER 6,4x12,5	
11	F0810505010	0	SPLIT PIN A2,0X201336	
12	58172946	0	CABLE	
13	59071778	0	BRACKET	
14	58071811	0	BUSHING	
15	59071779	0	COMMAND LEVER	
16	56371777	0	HINGE PIN	
17	59072678	0	SHIELD	
18	F0843643060	0	WASHER 8	
19	31111151	0	SCREW TE M8X16 UNI 5739 8G	
20	38110913	0	O-RING 109 (9,13X2,62)	
21	56372674	0	PULL ROD	
22	59072675	0	SELECTOR FORK	
23	F0851260000	0	PIN 6X24 DIN 1481	
24	58070205	0	SPRING	
25	F0843957000	0	WASHER D.25x14,5/2,2	
26	35121014	0	SEEGER RING E 14 DIN 471	
27	59073003	0	SUPPORT	
28	31111151	0	SCREW TE M8X16 UNI 5739 8G	
29	56372708	0	HINGE PIN	
30	59073509	0	PEDAL	
31	F0810527000	0	SPLIT PIN A2,5X25 UNI 1336	
32	F0803178000	0	O-RING 117	
33	56372696	0	PULL ROD	
34	51372697	0	FORK	

SERIAL

DIFFERENTIAL GEAR LOCK

CODE REV

D0901_1_19362



BLOCCAGGIO DIFFERENZIALE
DIFFERENTIAL GEAR LOCK
BLOCAGE DU DIFFERENTIEL
DIFFERENTIALSPERRE
BLOQUEO DEL DIFERENCIAL

Tavola	Rev.	Data
D.09.01	1	04/2002

1/1

RS	AR
•	•

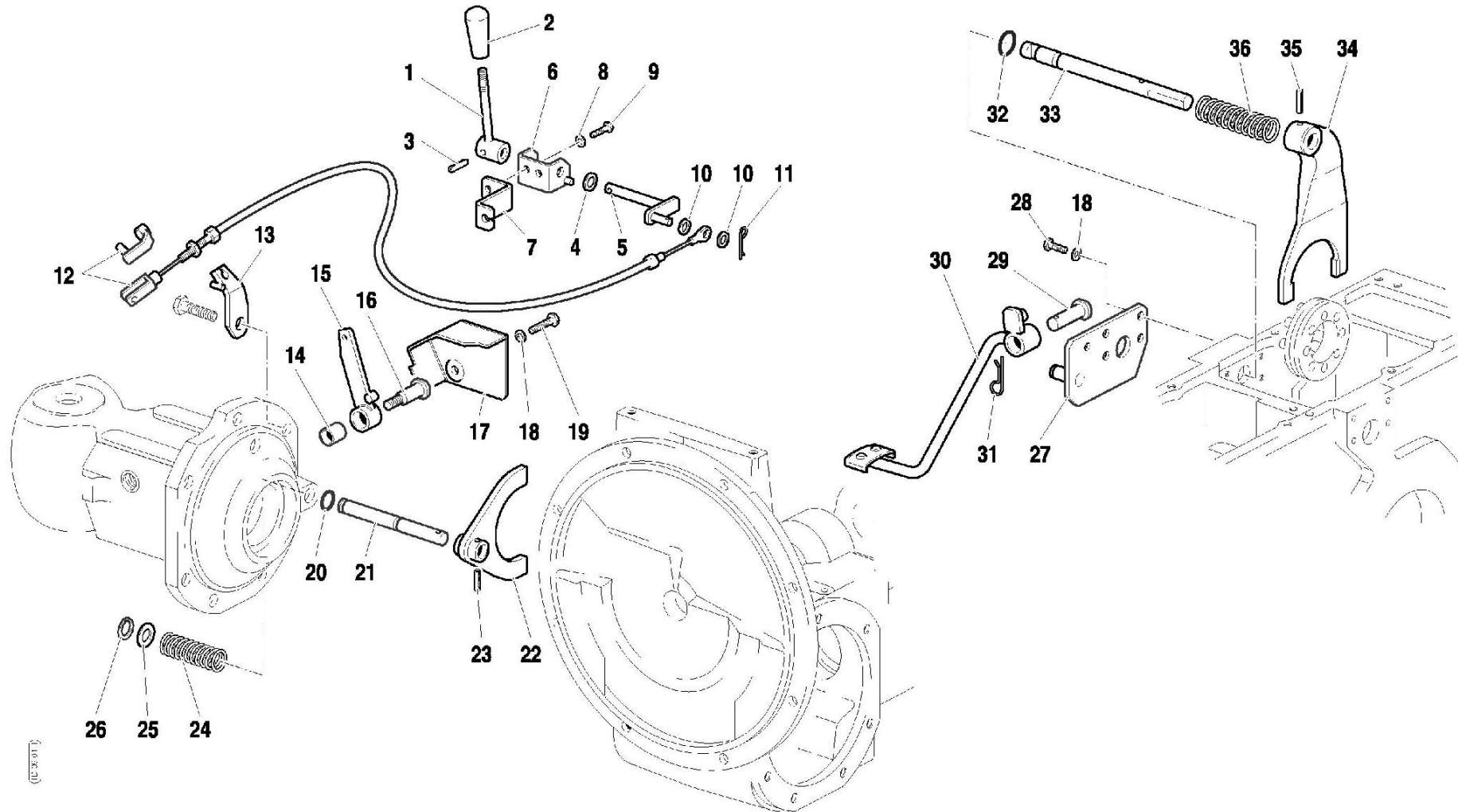

1023897

Pos.	Code	Q.ty	Description	Notes
35	F0851267050	0	PIN 6X30 DIN 7343 CL:C72	
36	58070198	0	SPRING	

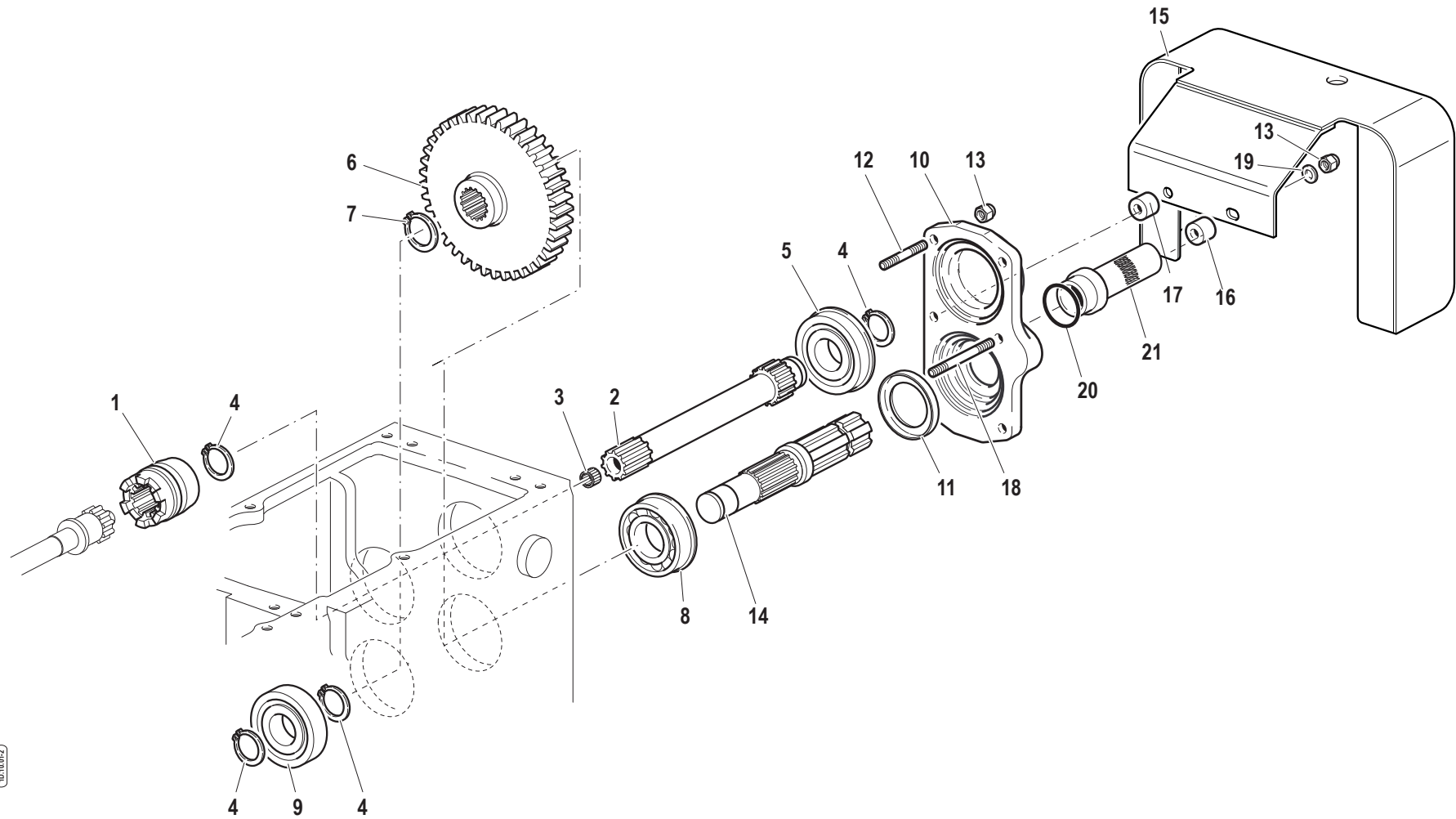

0110022

Pos.	Code	Q.ty	Description	Notes
1	52474190	1	GEAR SLEEVE	
2	52472933	1	PTO SHAFT	
3	F0812525100	1	BUSHING HK1210-B	
4	35121030	4	SEEGER RING E 30 DIN 471	
5	F0812779000	1	BEARING 6306-NR	
6	52474123	1	DRIVEN GEAR	
7	F0801264050	1	SEEGER RING E 35X2,5 U/7436	
8	F0812849100	1	BEARING 6207-NR	
9	37111303	1	BEARING	
10	51176022	1	COVER	
11	F0802190010	1	SEAL 42x62/7	
12	F0838131000	4	STUD BOLT M8X20 UNI 5911 8.8	
13	F0814574000	6	NUT M8	
14	52473521	1	SHAFT	
15	59075077	1	P.T.O. PROTECTION	
16	56172079	1	SPACER	
17	56172080	1	SPACER	
18	F0838166018	2	STUD BOLT M8X45 UNI 5911 8.8	
19	F0843643060	2	WASHER 8	
20	P47043300000	1	PROTECTIVE RING	
21	P47033000000	1	GUARD	



COMANDI PRESA DI FORZA
POWER TAKE-OFF CONTROLS
COMMANDES PRISE DE FORCE
ZAPFWELLE-STEUERUNGEN
MANDOS TOMA DE FUERZA

Tavola	Rev.	Data
D.11.01	1	04/2002

1/1

RS	AR
•	•

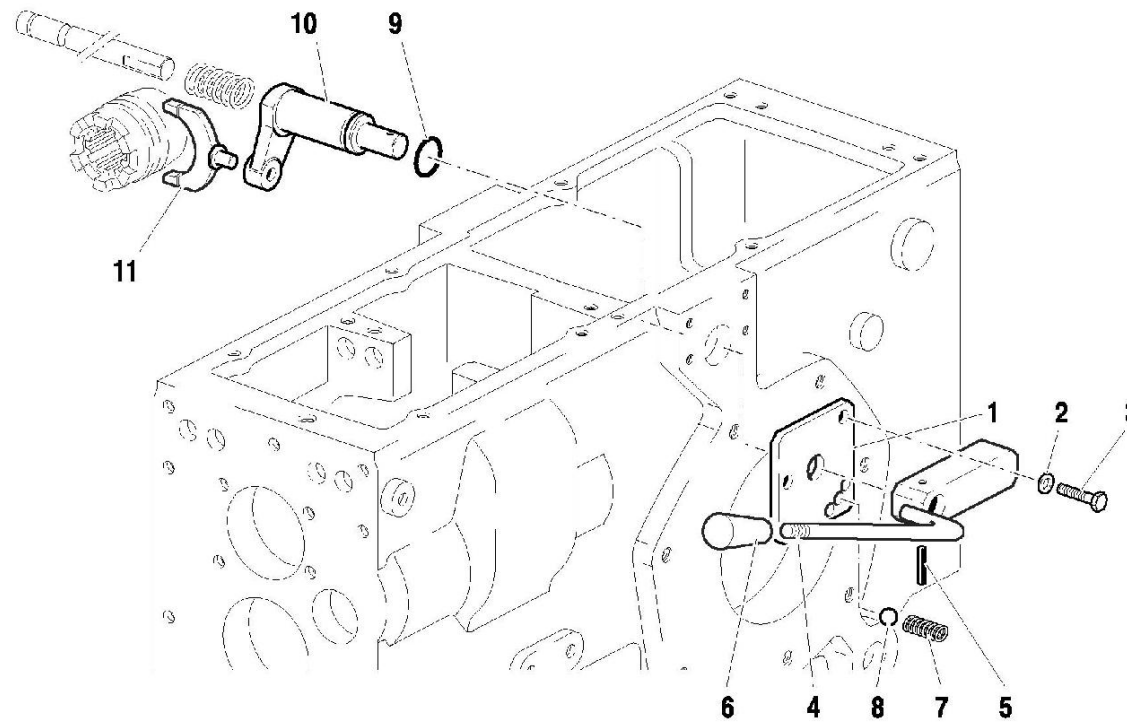

(D.11.01)

Pos.	Code	Q.ty	Description	Notes
1	59072754	0	PLATE	
2	F0843643060	0	WASHER 8	
3	31112150	0	SCREW TE M8X20 UNI 5739 8G	
4	59072761	0	LEVER	
5	34211054	0	ROLL PIN	
6	F0837534010	0	GRIP	
7	58070741	0	SPRING	
8	F0847434000	0	BALL	
9	38112200	0	O-RING 3087 (22,00X2,62)	
10	52371679	0	LEVER	
11	52472430	0	SELECTOR FORK	

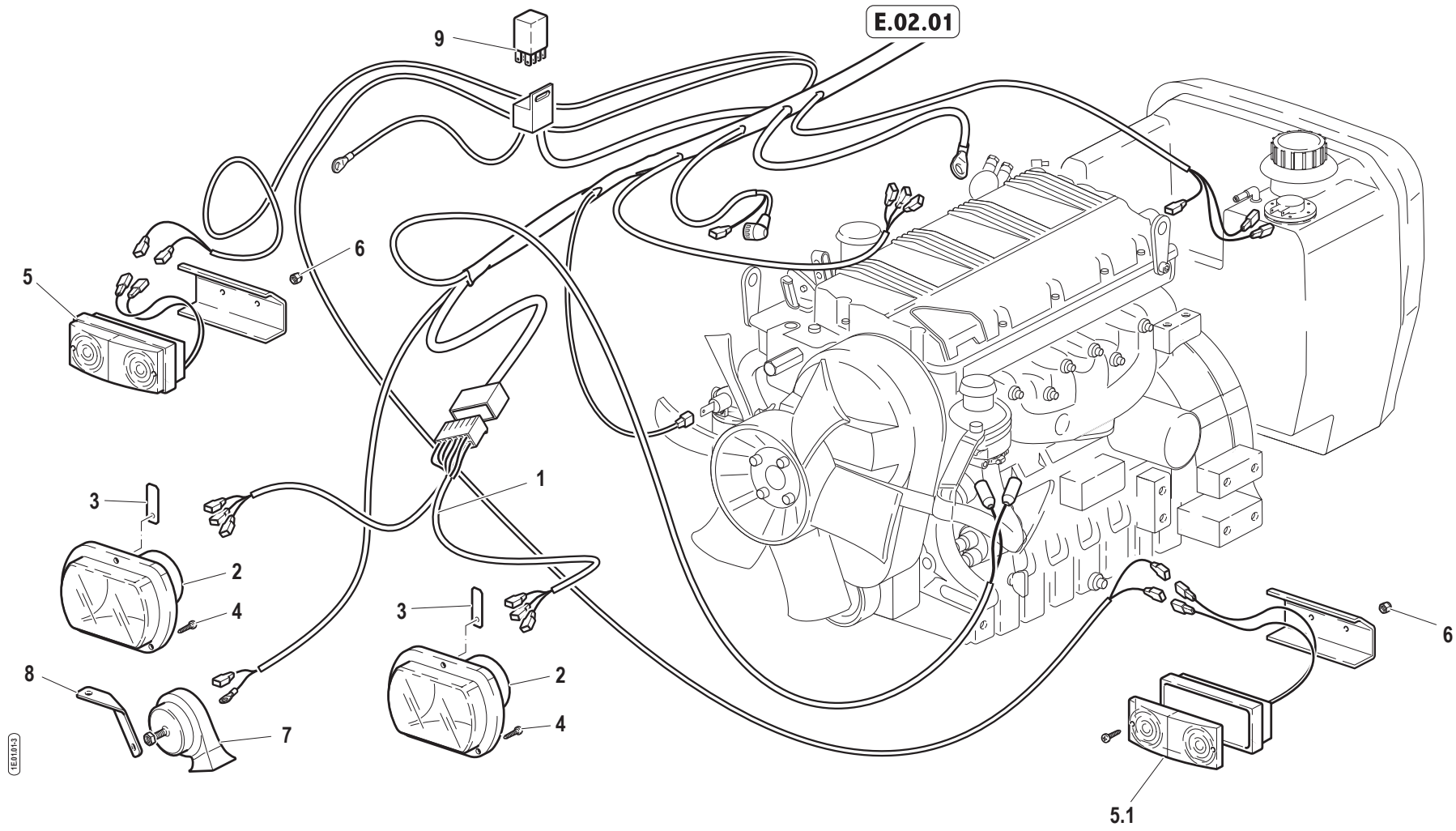

REMARKS

Pos.	Code	Q.ty	Description	Notes
1	58078988	1	CABLE	
2	F0825404050	2	HEADLIGHT	
3	56173748	2	CLAMP	
4	F1000005108	6	SCREW A/F TCB 7981 4,8X13 ZNT	
5	58078989	2	LAMP	
5.1	F0825420560	1	GLASS	
6	F0814529080	4	SELFLOCK NUT M5	
7	F0825417000	1	HORN	
8	56174160	1	SMALL PLATE	
9	F0834378001	1	CENTRAL PROCESSING UNIT	

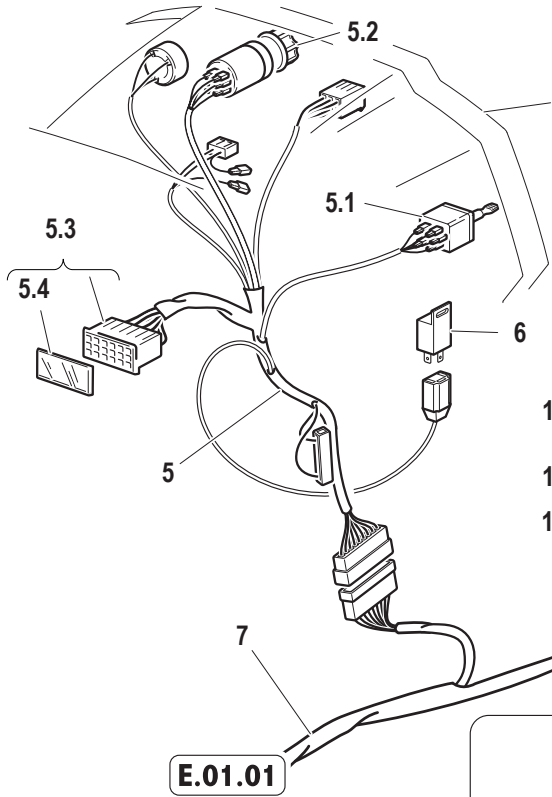

- VEDI ANCHE ...
 - SEE ALSO ...
 - VOIR AUSSI ...
 - SIEHE AUCH ...
 - VER TAMBIEN ...

B.05.01

- VARIANTE PROIETTORE POSTERIORE
 - TAIL WORKING LIGHT VERSION
 - VARIANTE PROJECTEUR ARRIERE DE TRAVAIL
 - VARIANTE HECKARBEITSSCHEINWERFER
 - VARIANTE PROYECTOR POST. DE TRABAJO

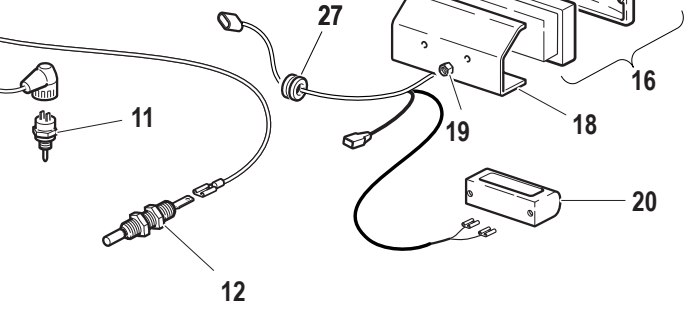
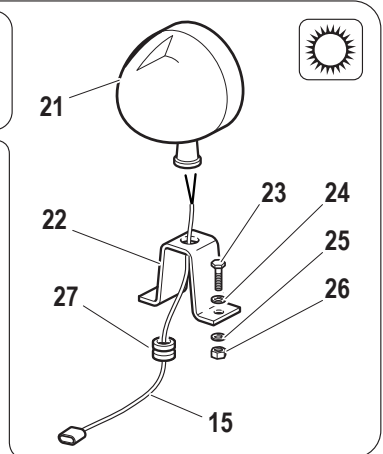
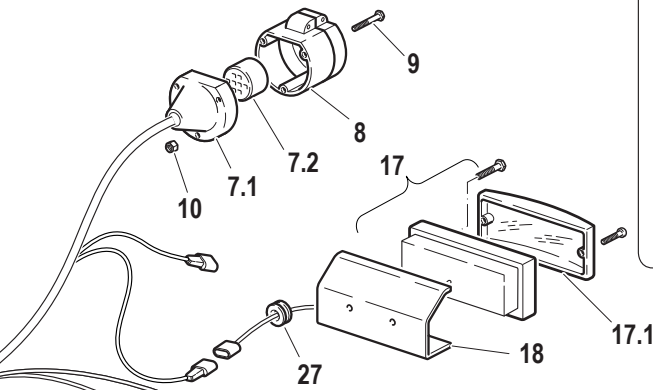
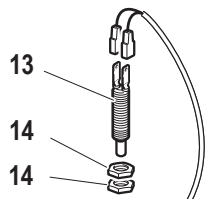
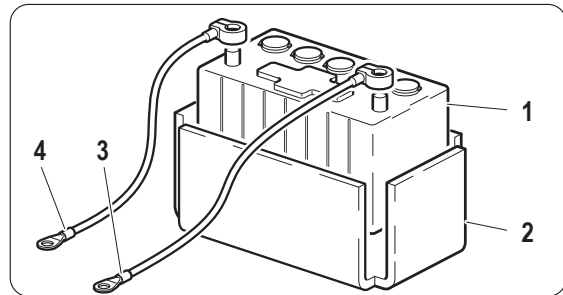

Pos.	Code	Q.ty	Description	Notes
1	F0825470050	1	BATTERY	
2	57373231	1	LINING	
3	58074023	1	CABLE	
4	58074024	1	CABLE	
5	58077816	1	CABLE	
5.1	F0825436000	1	SWITCH	
5.2	F0825436003	1	SWITCH	
5.3	58170453	1	FUSE BOX	
5.4	58172267	1	COVER	
6	F0825139000	1	FLASHER	
7	58078987	1	CABLE	
7.1	58170571	1	ATTACHMENT PLUG	
7.2	58170572	1	CAP	
8	F0825438000	1	SOCKET	
9	F0861941000	1	SCREW M5X35 UNI 6107	
10	31211050	1	NUT M5	
11	F0825117000	1	SWITCH	
12	F0825488000	1	SWITCH	
13	58173230	1	PUSH-BUTTON	
14	F0814744050	1	NUT M14X1,5	
15	58078992	1	CABLE	
16	58078990	1	LAMP	
17	58078991	1	LAMP	
17.1	F0825420660	1	GLASS	
18	56171938	1	BRACKET	
19	F0814529080	1	SELFLOCK NUT M5	
20	30000506	1	LAMP	
21	F0825493000	1	HEADLIGHT	
22	F0190035152	1	SUPPORT	
23	F0862488000	1	SCREW M8X16 UNI 5739	
24	F0843643060	1	WASHER 8	
25	F0843708000	1	WASHER 9x24/2	
26	F0814574000	1	NUT M8	
27	F0825414000	1	CABLE GLAND 7-15-18,5-2,5	

SERIAL

BATTERY AND REAR ELECTRICAL SYSTEM

CODE REV

E0201_2_49124

RS	AR
	•

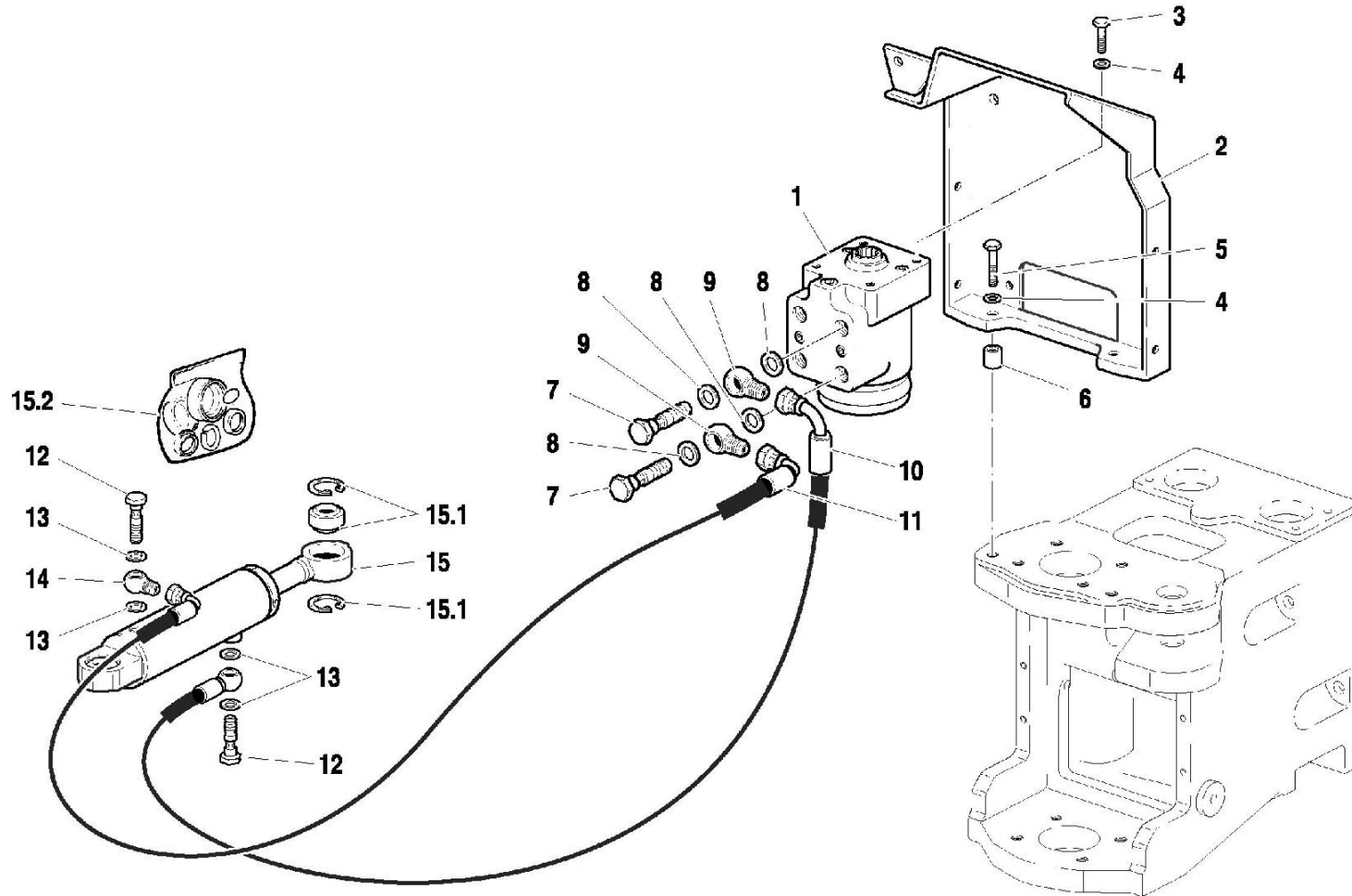

Pos.	Code	Q.ty	Description	Notes
1	58173164	0	HYDROSTEERING	
2	59072974	0	SUPPORT	
3	31112219	0	SCREW TE M10X25 UNI 5739	
4	F0843755000	0	WASHER 10	
5	31112214	0	SCREW TE M10X45 UNI 5739	
6	56171967	0	SPACER	
7	F0843116000	0	PIPE FITTING 1/2	
8	F0824141000	0	COPPER WASHER 21x27/1,5	
9	F0835040030	0	PIPE FITTING	
10	58073498	0	FLEXIBLE HOSE	
11	58073499	0	FLEXIBLE HOSE	
12	F0843109000	0	PIPE FITTING 14x1,5	
13	F0843948000	0	COPPER WASHER 14,0x20/1,5	
14	58170930	0	PIPE FITTING	
15	58174019	0	STEERING CYLINDER	
15.1	59900178	0	BUSHINGS KIT	
15.2	59900247	1	GASKET SET	



SOLLEVATORE IDRAULICO
HYDRAULIC LIFT
RELEVEUR HYDRAULIQUE
HYDRAULISCHE HEBER
ELEVADOR HIDRAULICO

Tavola	Rev.	Data
G.01.01	1	04/2002

1/1

RS	AR
•	•

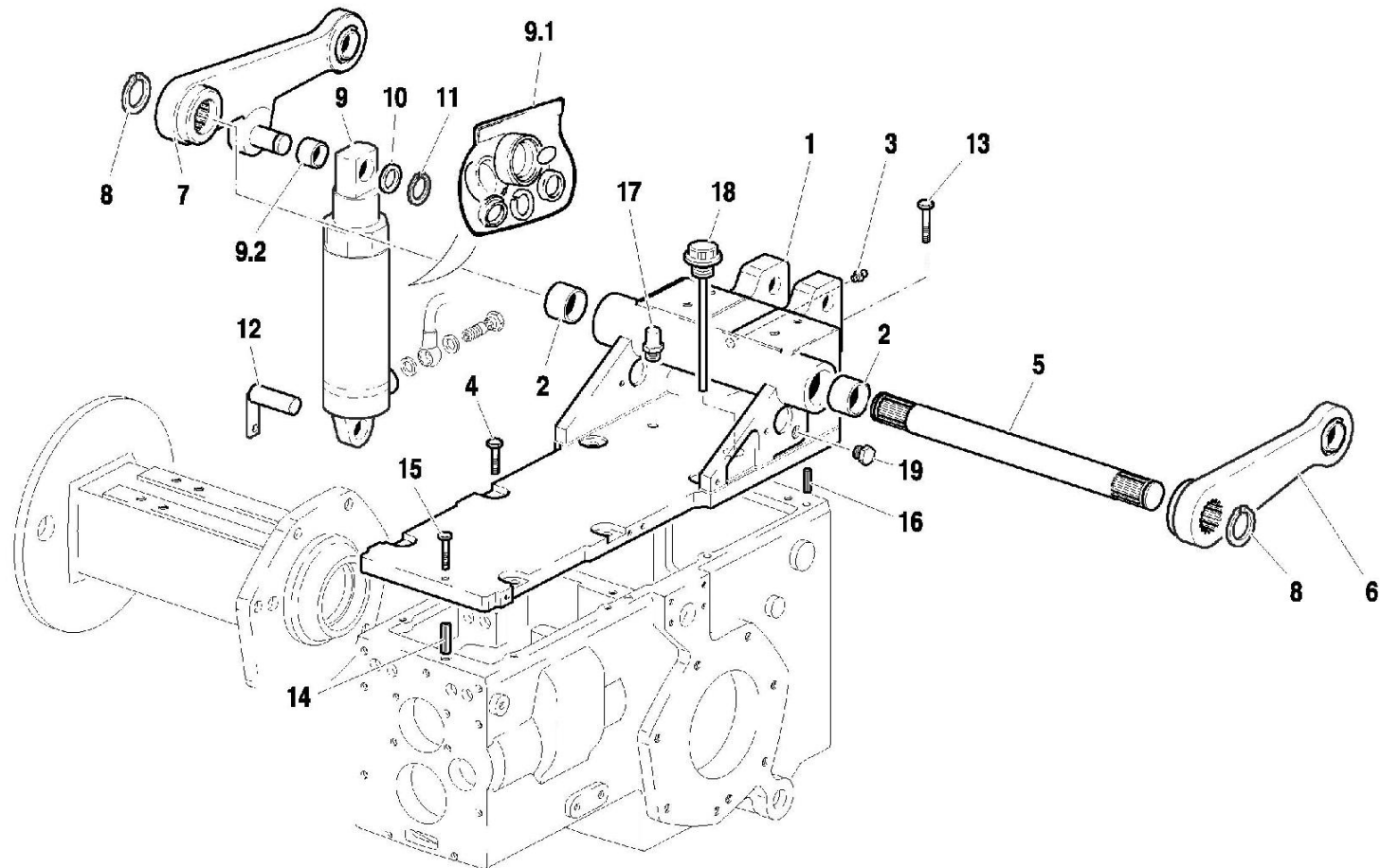

Pos.	Code	Q.ty	Description	Notes
1	51171641	0	SUPPORT	
2	58171861	0	BUSHING	
3	F0826056000	0	LUBRICATOR M10 UNI 7663A	
4	31112219	0	SCREW TE M10X25 UNI 5739	
5	56571785	0	SHAFT	
6	59072829	0	LIFTING ARM	
7	59072825	0	RIGHT ARM	
8	F0801264050	0	SEEGER RING E 35X2,5 U/7436	
9	58071534	0	LIFTING CYLINDER	
9.1	59900181	0	GASKET SET	
9.2	59900180	0	BUSHING	
10	56172905	0	THRUST PLATE	
11	F0801149010	0	SEEGER RING E 20 7436D/471-2	
12	59072722	0	PIN	
13	F0863328000	0	SCREW M10X35 UNI 5737	
14	56170017	0	PIN	
15	31112154	0	SCREW TE M8X40 UNI 5739 8G	
16	56370228	0	CYLINDRICAL PLUG	
17	30040005	0	PLUG	
18	58071805	0	PLUG	
19	58072045	0	PLUG	

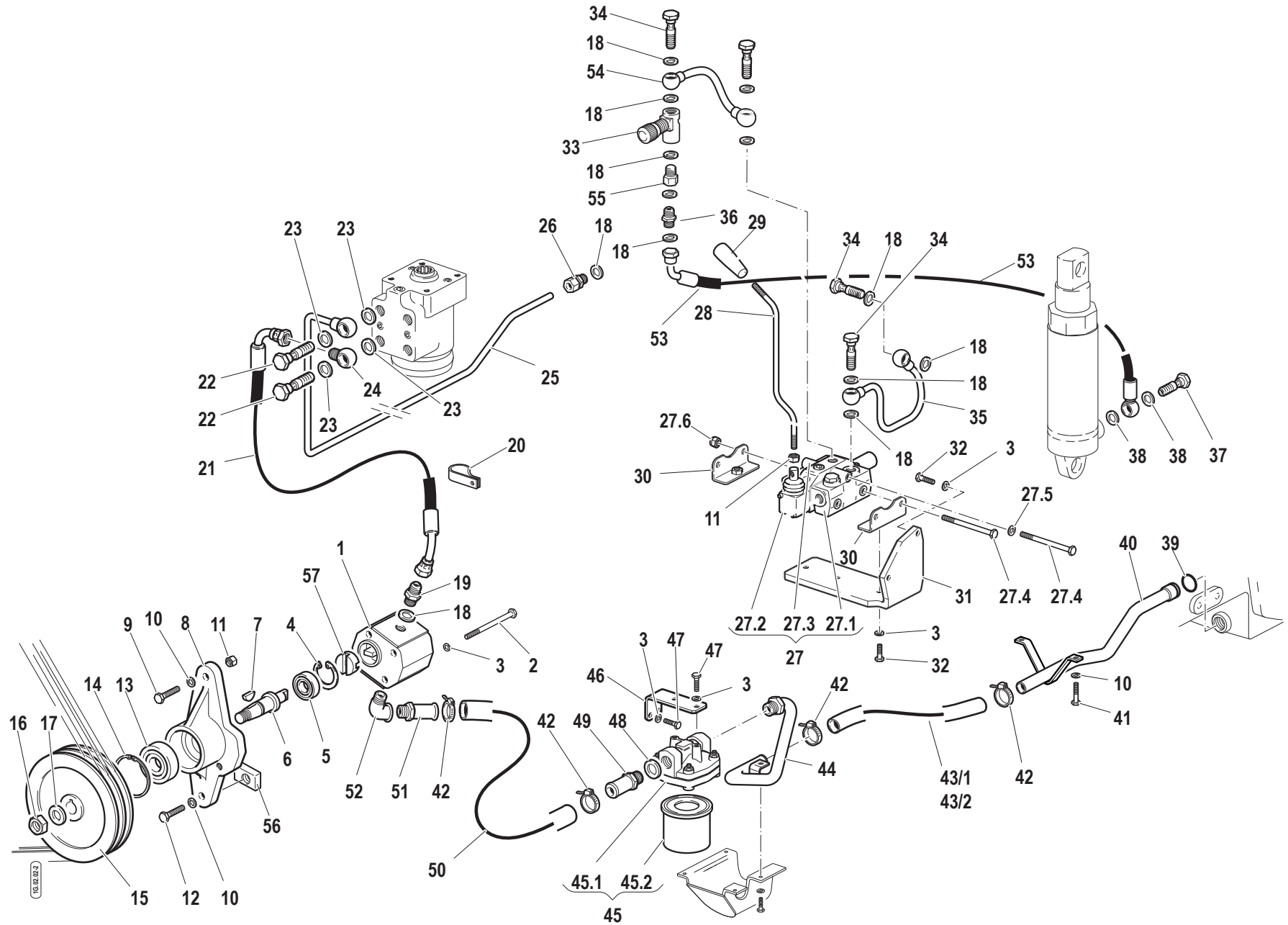

Pos.	Code	Q.ty	Description	Notes
1	58172911	1	PUMP	
2	F0863079000	2	SCREW M8X105 UNI 5737	
3	F0843643060	10	WASHER 8	
4	F0801127050	1	SEEGER RING E 17X1,5 U/7436	
5	F0812523050	1	BEARING 6201-2RS	
6	56372831	1	SHAFT	
7	58172914	1	KEY	
8	51172830	1	SUPPORT	
9	F0863449000	1	SCREW M10X50 UNI 5737	
10	F0843755000	4	WASHER 10	
11	31211100	2	NUT M10	
12	F0863359000	1	SCREW M10X40 UNI 5737	
13	37112172	1	BEARING	
14	35111047	1	SEEGER RING I 47 DIN 472	
15	51172832	1	PULLEY	
16	F0814688010	1	NUT M12X1,5	
17	58172915	1	WASHER	
18	F0824110000	12	COPPER WASHER 3/8 GAS	
19	F0835024010	1	NIPPLE	
20	F0825416000	1	CLAMP	
21	58073147	1	FLEXIBLE HOSE	
22	F0843116000	2	PIPE FITTING 1/2	
23	F0824141000	4	COPPER WASHER 21x27/1,5	
24	F0842512000	1	PIPE FITTING	
25	59074089	1	PRESSURE PIPE	
26	58172015	1	PIPE FITTING	
27	58173162	1	LIFT CONTROL VALVE	
27.01.00	58173518	1	HEAD	
27.02.00	58172011	1	S.A. VALVE	
27.03.00	58172489	1	COVER	
27.04.00	58172490	3	ROD	
27.05.00	F0843643060	1	WASHER 8	
27.06.00	31211080	3	NUT M8	
28	56172769	1	COMMAND LEVER	

SERIAL

HYDRAULIC SYSTEM

CODE REV

G0202_2_48619

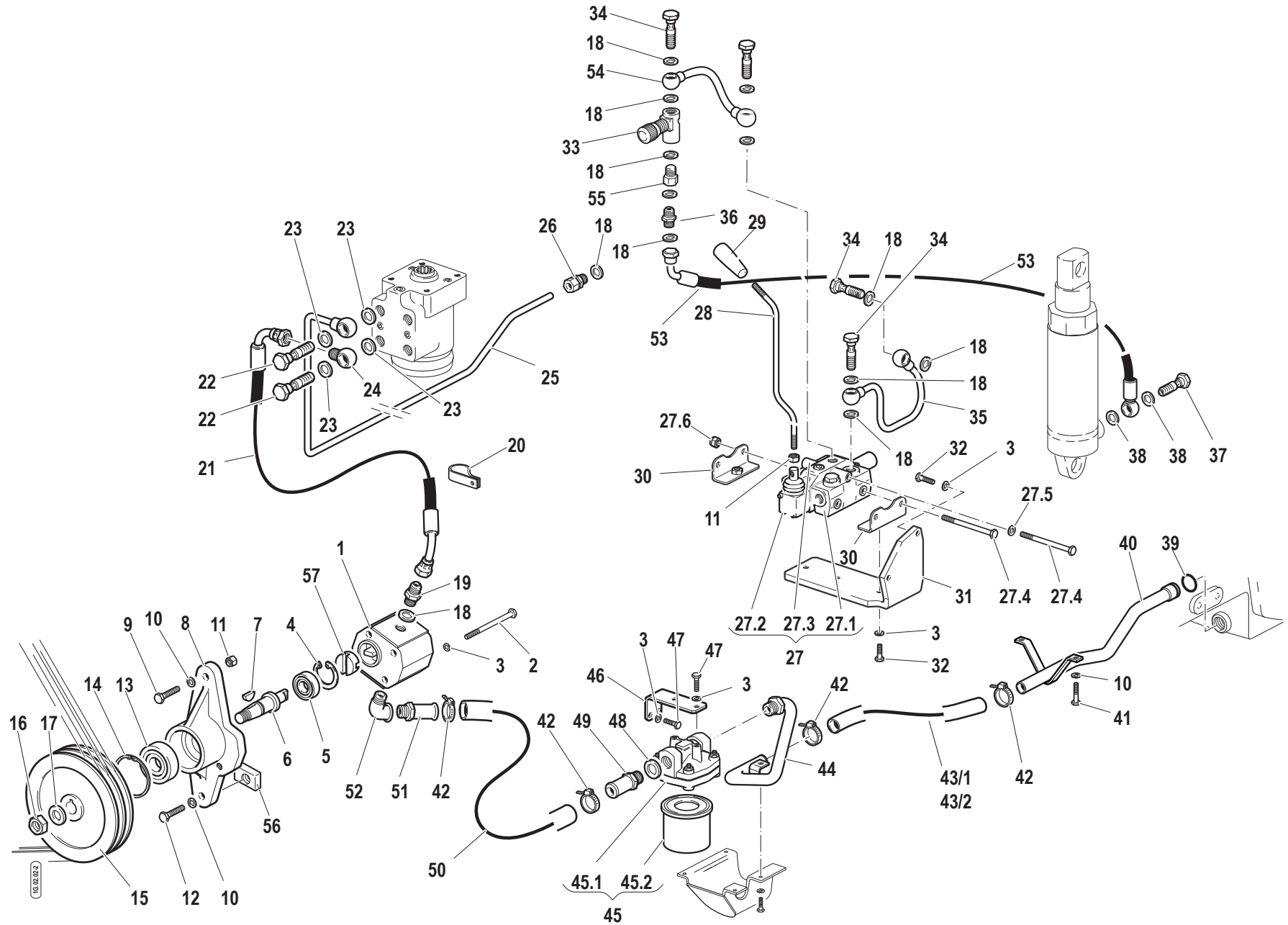

Pos.	Code	Q.ty	Description	Notes
29	F0837534010	1	GRIP	
30	59072057	2	FIXING BRACKET	
31	56173511	1	RETAINER	
32	31112150	4	SCREW TE M8X20 UNI 5739 8G	
33	P24117100000	1	VALVE	
34	F0843109020	4	PIPE FITTING	
35	59073320	1	EXHAUST	
36	F0835023000	1	NIPPLE	
37	F0843107000	1	PIPE FITTING GAS 1/4	
38	F0843907000	2	COPPER WASHER 13,66x19/1,5	
39	38112507	1	O-RING 3100 (25,07X2,62)	
40	59074878	1	SUCTION PIPE	
41	F0863276000	2	SCREW M10X30 UNI5739	
42	F0817523010	4	CLAMP	
43/1	58173507	1	FLEXIBLE HOSE	
43/2	58173515	1	FLEXIBLE HOSE	
44	59072408	1	SUCTION PIPE	
45	58173337	1	FILTER	
45.01.00	F0825718010	1	FILTER HEAD	
45.02.00	58173642	1	FILTER INSERT	
46	56173496	1	FILTER SUPPORT	
47	31111151	4	SCREW TE M8X16 UNI 5739 8G	
48	F0824185000	1	COPPER WASHER 26X34X1,5	
49	56170350	1	PIPE FITTING	
50	58170352	1	FLEXIBLE HOSE	
51	56172917	1	PIPE FITTING	
52	F0840544000	1	ELBOW	
53	58075373	1	FLEXIBLE HOSE	
54	59075386	1	PRESSURE PIPE	
55	30000200	1	EXTENSION	
56	56176373	1	LOCKING MECHANISM	
57	56477572	1	JOINT	

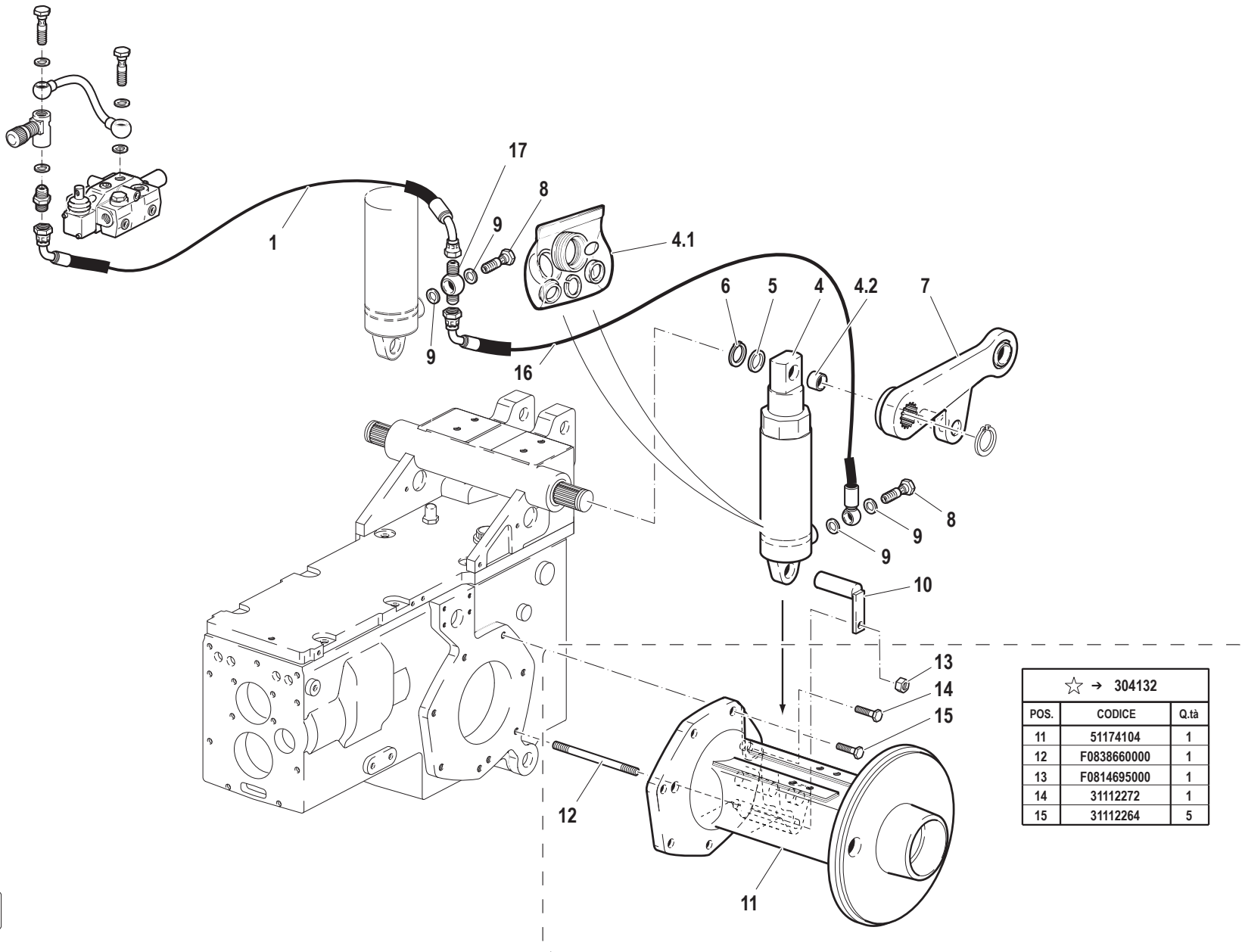

Pos.	Code	Q.ty	Description	Notes
1	58075372	1	FLEXIBLE HOSE	
4	58071534	1	LIFTING CYLINDER	
4.1	59900181	1	GASKET SET	
4.2	59900180	1	BUSHING	
5	56172905	1	THRUST PLATE	
6	F0801149010	1	SEEGER RING E 20 7436D/471-2	
7	59074105	1	LIFTING ARM	
8	F0843107000	2	PIPE FITTING GAS 1/4	
9	F0843907000	4	COPPER WASHER 13,66x19/1,5	
10	59072722	1	PIN	
11	51174104	1	REAR AXLE HOUSING	
12	F0838660000	1	STUD BOLT M12X105 UNI 5911-66	
13	F0814695000	1	NUT M12	
14	31112272	1	SCREW TE M12X30 UNI 5739	
15	31112264	5	SCREW TE M12X35 UNI 5739	
16	58072269	1	FLEXIBLE HOSE	
17	F0842519050	1	PIPE FITTING	



UN DISTRIBUTORE SUPPLEMENTARE PER "AR"
ONE ADDITIONAL CONTROL VALVE FOR "AR"
UN DISTRIBUTEUR SUPPLEMENTAIRE POUR "AR"
EIN ZUSATZSTEUERGERAT FÜR "AR" SCHLEPPER
UN DISTRIBUIDOR ADICIONAL PARA "AR"

Tavola	Rev.	Data
G.03.02	1	04/2002

1/1

RS	AR
	●

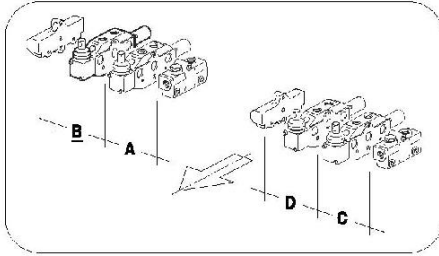

➔ - VEDI TAVOLA...
- SEE TABLE...
- VOIR TABLE...
- SIEHE TAFEL...
- MIRAR TABLA...
I.01.01

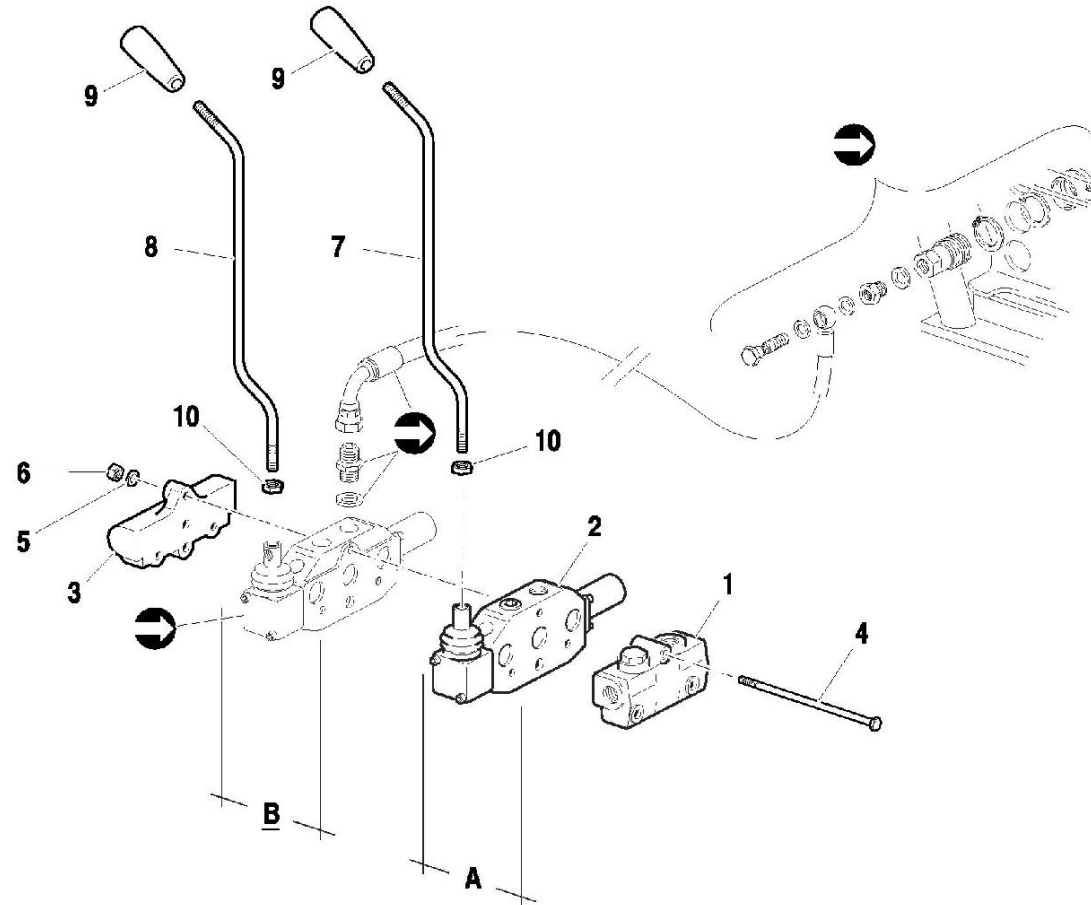

Pos.	Code	Q.ty	Description	Notes
1	58173518	0	HEAD	
2	58172011	0	S.A. VALVE	
3	58172489	0	COVER	
4	58172016	0	ROD	
5	F0843643060	0	WASHER 8	
6	31211080	0	NUT M8	
7	56172769	0	COMMAND LEVER	
8	56172770	0	COMMAND LEVER	
9	F0837534010	0	GRIP	
10	31211100	0	NUT M10	

SERIAL

ONE ADDITIONAL CONTROL VALVE FOR "AR"

CODE REV

G0302_1_19731

RS	AR
	•

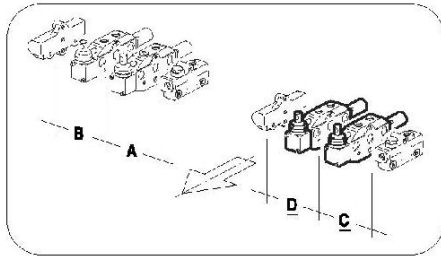

➡ - VEDI TAVOLA...
- SEE TABLE...
- VOIR TABLE...
- SIEHE TAFEL...
- MIRAR TABLA...
I.01.01

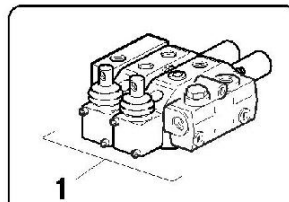

1
- GRUPPO DISTRIBUTORI CON "CARRY OVER"
- CONTROL VALVES UNIT WITH "CARRY OVER"
- GROUPE DES DISTRIBUTEURS AVEC "CARRY OVER"
- STEUERGERÄTEGRUPPE MIT "CARRY OVER"
- GRUPO DISTRIBUIDORES CON "CARRY OVER"

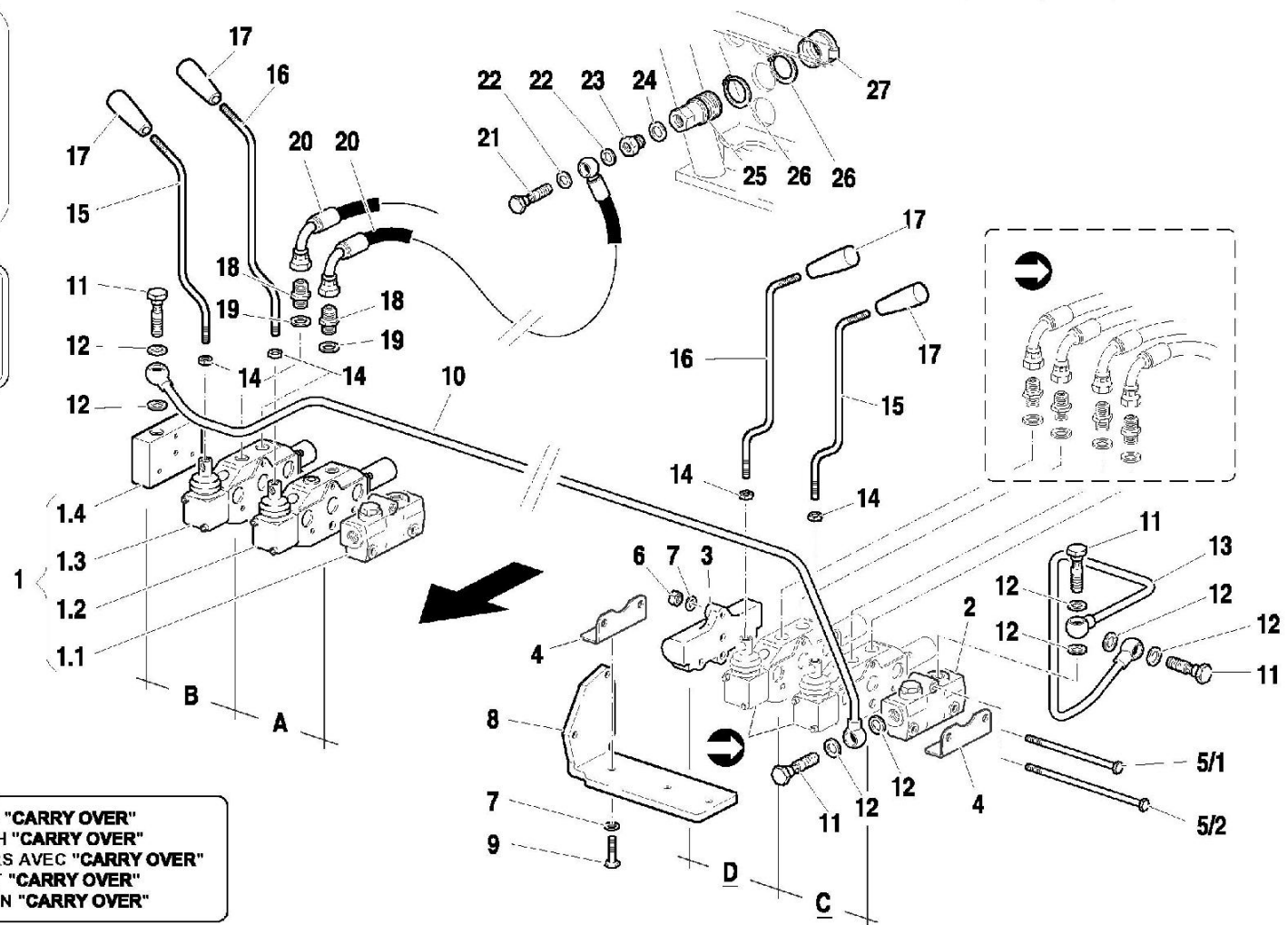

Pos.	Code	Q.ty	Description	Notes
1	58173519	0	UNIT	
1.1	58173518	0	HEAD	
1.2	58172011	0	S.A. VALVE	
1.3	58172012	0	D.A. VALVE	
1.4	58173361	0	COVER	
3	58172489	0	COVER	
4	59072057	0	FIXING BRACKET	
5/1	58172490	0	ROD	
5/2	58172016	0	ROD	
6	31211080	0	NUT M8	
7	F0843643060	0	WASHER 8	
8	56172750	0	RETAINER	
9	31112146	0	SCREW TE M8X22 UNI 5739 8G	
10	59072786	0	PIPE	
11	F0843109020	0	PIPE FITTING	
12	F0824110000	0	COPPER WASHER 3/8 GAS	
13	59072787	0	EXHAUST	
14	31211100	0	NUT M10	
15	56172770	0	COMMAND LEVER	
16	56172769	0	COMMAND LEVER	
17	F0837534010	0	GRIP	
18	F0835023000	0	NIPPLE	
19	F0824110000	0	COPPER WASHER 3/8 GAS	
20	58072138	0	FLEXIBLE HOSE	
21	F0843107000	0	PIPE FITTING GAS 1/4	
22	F0843907000	0	COPPER WASHER 13,66x19/1,5	
23	F0835040020	0	REDUCTION	
24	F0824141000	0	COPPER WASHER 21x27/1,5	
25	F0825980030	0	COUPLING	
26	F0801297000	0	SEEGER RING E 40 UNI 7435	
27	F0852550010	0	GUARD	

SERIAL

TWO OR THREE ADDITIONAL CONTROL VALVES FOR "AR"

CODE REV

G0303_1_19742



DISTRIBUTORI AUSILIARI
 AUXILIARY CONTROL VALVES
 DISTRIBUTEURS AUXILIARES
 HILFSSTEUERGERÄTE
 DISTRIBUIDORES AUXILIARIO

Tavola	Rev.	Data
I.01.01	1	04/2002

1/1

RS	AR
•	•

DISTRIBUTORI DISPONIBILI
 AVAILABLE CONTROL VALVES
 DISTRIBUTEURS DISPONIBLES
 VERFÜGBAR STEUERGERÄTE
 DISTRIBUIDORES DISPONIBLES

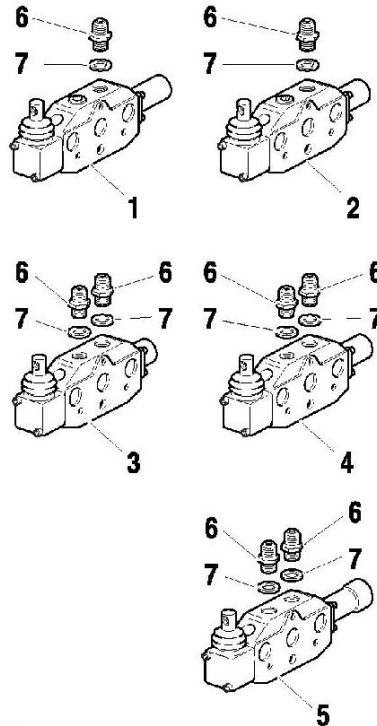

(1/1/02)

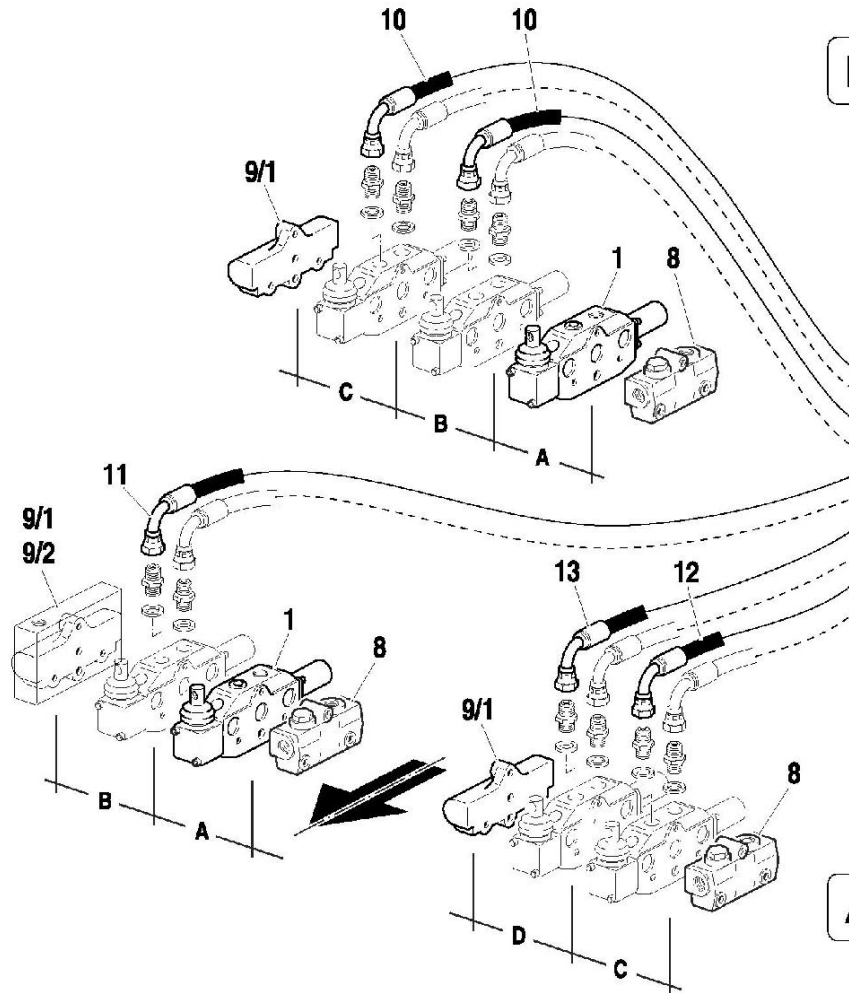

RS

AR

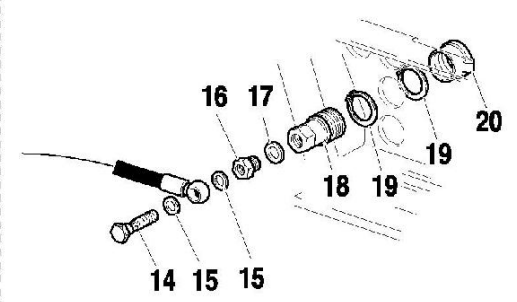

Pos.	Code	Q.ty	Description	Notes
1	58172011	0	S.A. VALVE	
2	58172707	0	S.A. VALVE	
3	58172012	0	D.A. VALVE	
4	58172013	0	D.A. VALVE	
5	58172014	0	D.A. VALVE	
6	F0835023000	0	NIPPLE	
7	F0824110000	0	COPPER WASHER 3/8 GAS	
8	58173518	0	HEAD	
9/1	58172489	0	COVER	
9/2	58173361	0	COVER	
10	58072138	0	FLEXIBLE HOSE	
12	58072795	0	FLEXIBLE HOSE	
13	58072796	0	FLEXIBLE HOSE	
14	F0843107000	0	PIPE FITTING GAS 1/4	
15	F0843907000	0	COPPER WASHER 13,66x19/1,5	
16	F0835040020	0	REDUCTION	
17	F0824141000	0	COPPER WASHER 21x27/1,5	
18	F0825980030	0	COUPLING	
19	F0801297000	0	SEEGER RING E 40 UNI 7435	
20	F0852550010	0	GUARD	



ATTACCO ATTREZZI
ATTACHMENT HITCH
ATTELAGE OUTILS
ANSCHLUSSTELLE FÜR AUSTRÜSTUNGEN
ENGANCHE HERRAMIENTAS

Tavola	Rev.	Data
L.01.01	1	04/2002

1/1

RS	AR
•	•

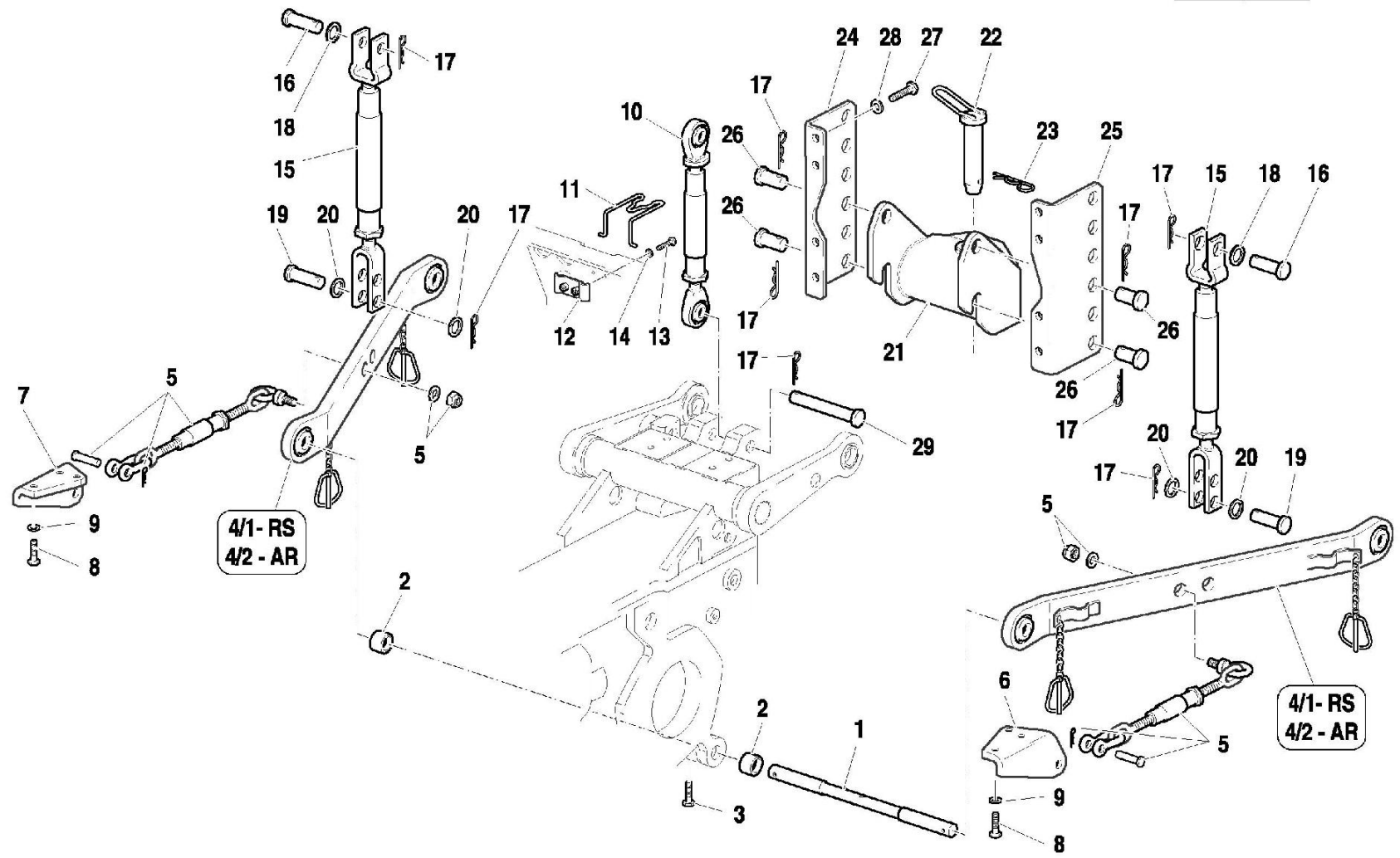

(-0-01)

Pos.	Code	Q.ty	Description	Notes
1	56571824	0	PIN	
2	F0844283020	0	SPACER D.38x22/22	
3	F0862488000	0	SCREW M8X16 UNI 5739	
4/1	59072913	0	BOTTOM LINK	
4/2	59073491	0	BOTTOM LINK	
5	58071998	0	ROD	
6	56072919	0	SUPPORT	
7	56072918	0	SUPPORT	
8	31112211	0	SCREW TE M10X30 UNI 5739	
9	F0843755000	0	WASHER 10	
10	F0060031247	0	3-POINT HITCH	
11	58170449	0	RETAINING SPRING	
12	59070448	0	FIXING BRACKET	
13	31112150	0	SCREW TE M8X20 UNI 5739 8G	
14	F0843643060	0	WASHER 8	
15	58072922	0	ROD	
16	58072642	0	PIN	
17	F0851486000	0	SPLIT PIN	
18	F0844179010	0	WASHER 18	
19	56372925	0	PIN	
20	F0844065010	0	WASHER 16	
21	F0190031203	0	TOW HOOK	
22	F0808060100	0	LATCH D.28X117	
23	F0851497000	0	SPLIT PIN	
24	56171789	0	SUPPORT	
25	56171788	0	SUPPORT	
26	56372067	0	PIN	
27	31112272	0	SCREW TE M12X30 UNI 5739	
28	F0843843060	0	WASHER 12	
29	56371210	0	CONNECTING BOLT	

SERIAL

ATTACHMENT HITCH

CODE REV

L0101_1_19795



GANCIO DI TRAINO OMOLOGATO "CEE"
DRAWBAR "EEC" TYPE APPROVED
BARRE D'ATTELAGE HOMOLOGUÉE "CEE"
ZUGSTANGE "EWG" FREIGEgeben
BARRA DE ARRASTRAMIENTO HOMOLOGADA "CEE"

Tavola	Rev.	Data
L.02.01	0	04/2002

1/1

RS	AR
•	•

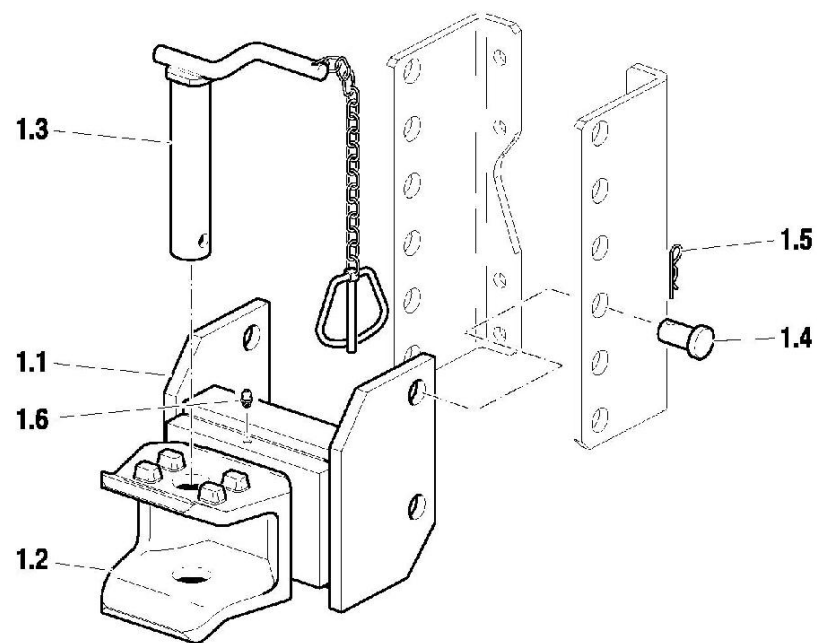
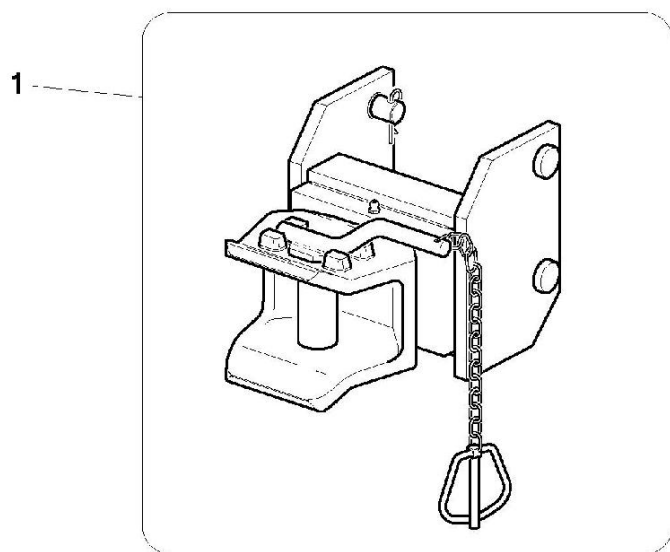

Pos.	Code	Q.ty	Description	Notes
1	59375017	0	TOW HOOK	
1.1	56075018	0	HOOK HINGING GROUP	
1.2	51175011	0	EEC HOMOLOGATED HOOK	
1.3	59075012	0	PIN	
1.4	56377980	1	PIN	
1.5	F0851486000	0	SPLIT PIN	
1.6	F0826056000	0	LUBRICATOR M10 UNI 7663A	

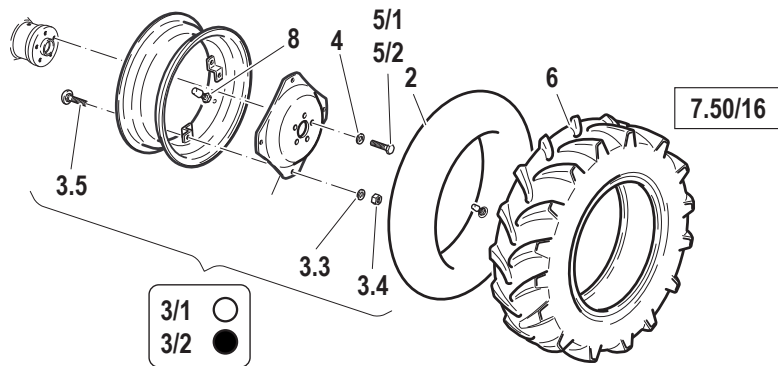
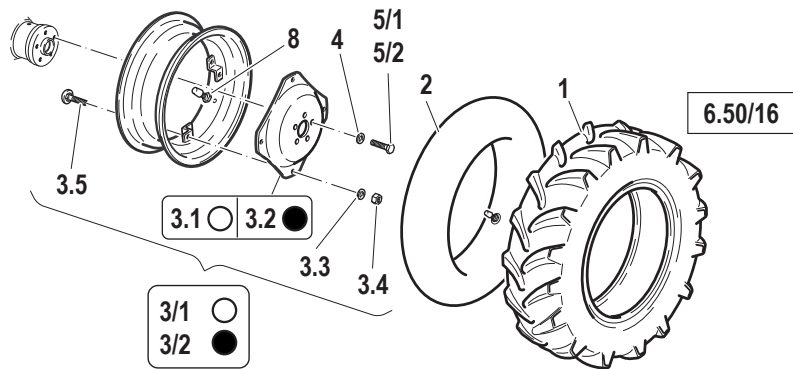

○ COLORE GIALLO
YELLOW COLOUR
COULEUR JAUNE
GELBE FARBE
COLOR AMARILLO

● COLORE GRIGIO
GREY COLOUR
COULEUR GRISE
GRAU FARBE
COLOR GRIS

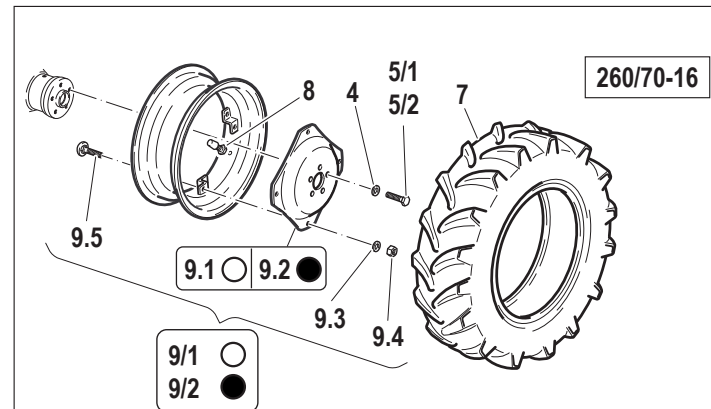

OK SOLO CON CARREGGIATE COMPRESSE 882+1026 (MM) INCLUSI GLI ESTREMI

OK ONLY WITH TRACK BETWEEN 882+1026 (MM) INCLUDING THOSE GIVEN

OK SEULEMENT AVEC CHAUSSEÉS ENTRE 882+1026 (MM) INCLUS CEUX-CI

OK NUR MIT 882+1026 (MM) SPURWEITE

OK SOLO CON CARRILLADA INCLUIDA ENTRE 882+1026 (MM) INCLUYENDO LOS MISMOS

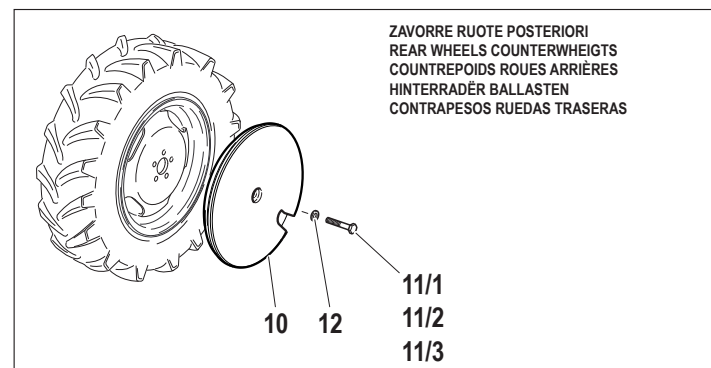

ZAVORRE RUOTE POSTERIORI
REAR WHEELS COUNTERWEIGHTS
COUTREPOIDS ROUES ARRIÈRES
HINTERRADÈR BALLASTEN
CONTRAPESOS RUEDAS TRASERAS

Pos.	Code	Q.ty	Description	Notes
1	F0848610000	1	TYRE 6.50-16 4PR	
2	F0848887000	1	INNER TUBE	
3/1	59275710	1	RIM	
3.1	56075715	1	WHEEL DISC	
3.2	56075970	1	WHEEL DISC	
3/2	59275709	1	RIM	
3.3	31411150	4	WASHER 15x28	
3.4	F0814751000	4	NUT M14	
3.5	F0864200000	4	SCREW M14X35 UNI 5739	
4	56573708	5	WASHER D.28x14,5/3,5	
5/1	F0864176000	5	SPECIAL SCREW TE M14x1,5/25	
5/2	F0864192000	5	SCREW TE M14x1,5/35	
6	F0848635000	1	TYRE 7.50-16 8PR	
7	F0848649000	1	TYRE 260/70R16	
8	F0150010905	1	VALVE	
9/1	58174451	1	RIM	
9.1	56075715	1	WHEEL DISC	
9/2	58174453	1	RIM	
9.2	56075970	1	WHEEL DISC	
9.3	31411150	4	WASHER 15x28	
9.4	F0814751000	4	NUT M14	
9.5	F0864200000	4	SCREW M14X35 UNI 5739	
10	51176070	1	BALLAST	
11/1	F0864364000	1	SCREW M16X60 UNI 5737	
11/2	31112446	1	SCREW TE M16X120UNI5737	
11/3	F0864403000	1	SCREW M16X150 UNI 5737	
12	F0844084000	1	WASHER D.35x17/4	

QUESTE VARIANTI NON SONO COMPATIBILI CON LE ZAVORRE RUOTE POSTERIORI
 THESE VERSIONS ARE INCOMPATIBLE WITH THE REAR WHEELS COUNTERWEIGHTS
 CES VARIANTES SONT INCOMPATIBLES AVEC LES COUNTERPOIDS ROUES ARRIÈRES
 DIESE VARIANTEN SIND MIT DEN HINTERRADÄR BALLASTEN UNVEREINBAR
 ESTAS VARIANTES SON INCOMPATIBLES CON LOS CONTRAPESOS RUEDAS ANTERIORAS

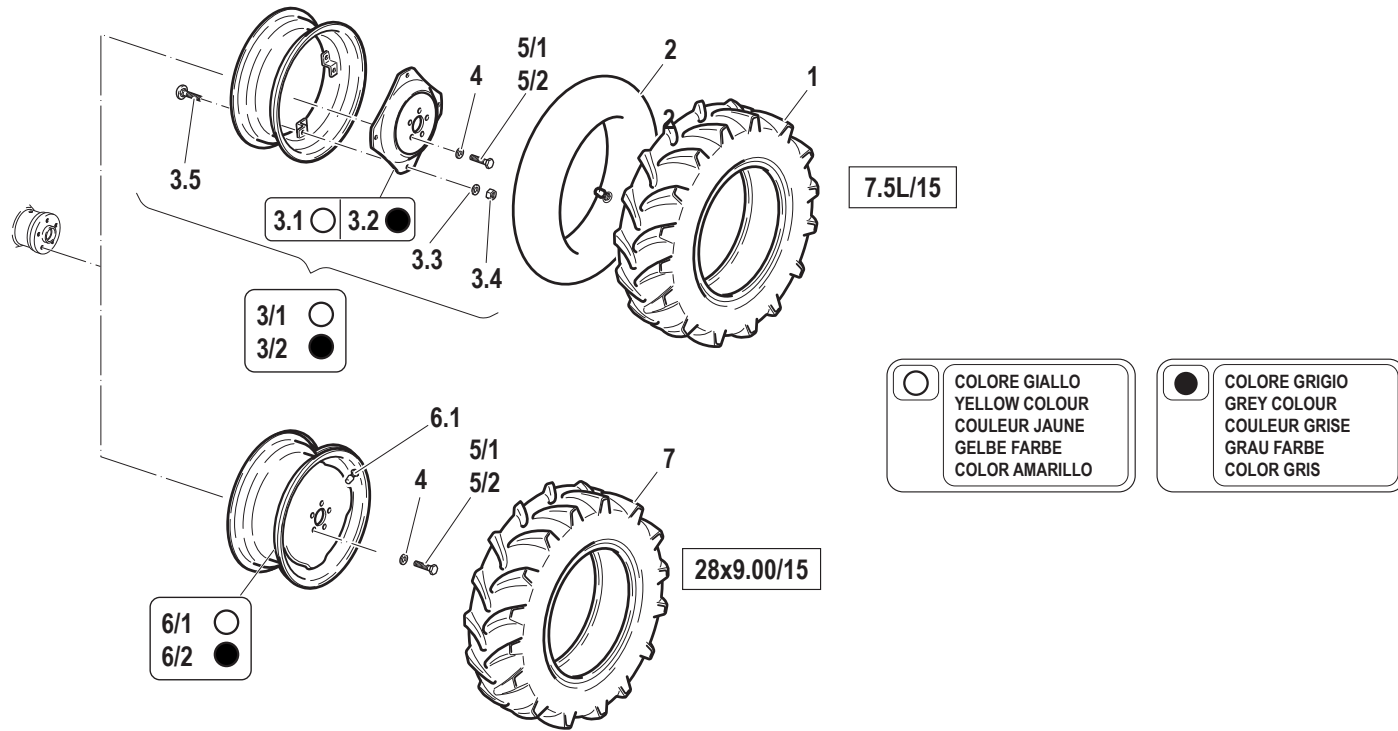

Pos.	Code	Q.ty	Description	Notes
1	F0848629000	1	TYRE 7.5L15 8PR	
2	39416021	1	INNER TUBE	
3.1	58173358	1	DISC	
3/1	58178910	1	RIM	
3.2	58175971	1	DISC	
3/2	58178909	1	RIM	
3.3	31411150	4	WASHER 15x28	
3.4	F0814751000	4	NUT M14	
3.5	F0864200000	4	SCREW M14X35 UNI 5739	
4	56573708	5	WASHER D.28x14,5/3,5	
5/1	F0864176000	5	SPECIAL SCREW TE M14x1,5/25	
5/2	F0864192000	5	SCREW TE M14x1,5/35	
6.1	F0150010905	1	VALVE	
6/1	58176203	1	RIM	
6/2	58176204	1	RIM	
7	F0150010910	1	WHEEL 28X9.0-15/8 TLB3	

SPARE PARTS INSTANCE INDEX





SPARE PARTS INSTANCE INDEX

Code	Parts Table	Pos.	Q.ty	Code	Parts Table	Pos.	Q.ty	Code	Parts Table	Pos.	Q.ty
30000007	C0202_2_48288	9	2	31112148	B0202_5_49540	26	6	31112264	C0102_1_19033	12	0
30000200	G0202_2_48619	55	1	31112150	A0201_1_18536	5	0		C0301_1_19119	9	0
30000506	E0201_2_49124	20	1		D1101_1_19419	3	0		G0203_1_48686	15	5
30000514	B0202_2_18795	39	0		G0202_2_48619	32	4	31112271	B0202_2_18795	4	0
	B0202_5_49540	46	1		L0101_1_19795	13	0	31112272	B0101_2_18644	16	0
30000614	B0501_2_48249	17	1	31112151	B0202_5_49540	40	8		B0202_5_49540	38	8
30040005	G0101_1_19551	17	0		D0201_2_48405	28	1		C0301_1_19119	8	0
31111090	C0102_1_19033	14	1		D0401_1_48440	30	1		G0203_1_48686	14	1
31111091	D0201_2_48405	3	1	31112153	B0202_2_18795	5	0		L0101_1_19795	27	0
31111097	A0401_1_18577	9	0		B0202_5_49540	5	4	31112293	B0202_2_18795	36	0
31111151	B0202_2_18795	32	0	31112154	G0101_1_19551	15	0	31112446	M0102_2_48797	11/2	1
	B0603_0_51086	10	5	31112210	A0501_2_47963	14	1	31121560	B0202_2_18795	11	0
	C0202_2_48288	18	1		B0202_2_18795	21	0		B0202_5_49540	11	4
	D0901_1_19362	19	0		B0202_5_49540	21	2	31132562	A0201_1_18536	2	0
	D0901_1_19362	28	0	31112211	B0202_2_18795	22	0		C0202_2_48288	40	4
	G0202_2_48619	47	4		B0202_5_49540	22	2	31132566	A0201_1_18536	6	0
31112082	A0401_1_18577	10	0		C0102_1_19033	3	0	31152101	C0102_1_19033	4	0
	C0202_2_48288	35	7		C0202_2_48288	6	4	31211050	E0201_2_49124	10	1
31112087	B0202_2_18795	15	0		L0101_1_19795	8	0	31211060	A0301_1_47945	9	2
	B0202_5_49540	15	2	31112212	D0701_2_48498	29	2		B0202_2_18795	14	0
31112090	A0301_1_47945	6	1	31112214	C0102_1_19033	2	0		B0202_5_49540	14	6
	B0501_2_48249	7	1		F0102_1_19533	5	0		B0501_2_48249	10	1
	B0701_1_18971	3	0	31112219	A0101_1_18484	3	0	31211080	A0101_1_18484	13	0
	C0202_2_48288	45	1		A0102_1_18510	3	0		A0102_1_18510	13	0
	D0201_2_48405	13	1		B0202_2_18795	30	0		A0301_1_47945	3	2
31112093	D0901_1_19362	9	0		B0202_2_18795	44	0		G0202_2_48619	27.06.00	3
31112146	G0303_1_19742	9	0		B0202_5_49540	30	4		G0302_1_19731	6	0
31112147	A0101_1_18484	10	0		B0202_5_49540	44	2		G0303_1_19742	6	0
	A0102_1_18510	10	0		C0301_1_19119	11	0	31211100	G0202_2_48619	11	2
	A0501_2_47963	13	1		F0102_1_19533	3	0		G0302_1_19731	10	0
31112148	A0101_1_18484	5	0		G0101_1_19551	4	0		G0303_1_19742	14	0
	A0102_1_18510	5	0	31112224	A0501_2_47963	10	1	31231080	A0201_1_18536	9	0
	A0201_1_18536	16	0	31112254	B0202_2_18795	34	0	31241080	A0501_2_47963	7	1
	B0202_2_18795	26	0	31112264	B0202_5_49540	49	4	31241140	B0202_5_49540	37	2



SPARE PARTS INSTANCE INDEX

Code	Parts Table	Pos.	Q.ty	Code	Parts Table	Pos.	Q.ty	Code	Parts Table	Pos.	Q.ty
31411064	B0202_2_18795	13	0	35121030	D1001_2_48472	4	4	51176022	D1001_2_48472	10	1
	B0202_5_49540	13	6	35211060	B0101_2_18644	11	0	51176070	M0102_2_48797	10	1
	B0501_2_48249	9	1	37111255	C0202_2_48288	33	1	51179815	C0202_2_48288	16	1
	D0901_1_19362	10	0	37111303	D1001_2_48472	9	1	51272728	D0701_2_48498	17	1
31411084	B0202_2_18795	6	0	37111404	D0102_1_19161	27	0	51272729	D0701_2_48498	18	1
	B0202_5_49540	6	10		D0801_1_19338	15	0	51272730	D0701_2_48498	19	1
	B0501_2_48249	5	1	37112172	G0202_2_48619	13	1	51273377	C0102_1_19033	11	0
	B0601_1_18928	4	0	37112249	C0202_2_48288	28	1	51273378	C0102_1_19033	10	0
	D0401_1_48440	10	1	37221300	D0102_1_19161	10	0	51372697	D0901_1_19362	34	0
31411104	D0901_1_19362	4	0	37320155	D0501_1_19263	8	0	51374866	D0102_1_19161	20	0
31411105	A0101_1_18484	4	0	38104412	C0202_2_48288	22	4	51374867	D0801_1_19338	10	0
	A0102_1_18510	4	0	38110913	D0901_1_19362	20	0	52172158	C0202_2_48288	11	1
	D0201_2_48405	20	1	38112200	D1101_1_19419	9	0	52172159	C0202_2_48288	11	1
	D0401_1_48440	21	1	38112507	G0202_2_48619	39	1	52172160	C0202_2_48288	11	1
31411130	B0101_2_18644	18	0	38112670	D0102_1_19161	6	0	52172161	C0202_2_48288	11	1
31411150	D0401_1_48440	28	1	38212003	D0601_1_19281	1	0	52172162	C0202_2_48288	11	1
	M0102_2_48797	3.3	4	39416021	M0201_1_49600	2	1	52371679	D1101_1_19419	10	0
	M0102_2_48797	9.3	4	41N40003	A0101_1_18484	1	0	52373346	D0301_1_19222	6	0
	M0201_1_49600	3.3	4	41N50003	A0102_1_18510	1	0	52379809	C0202_2_48288	7	2
31424064	B0202_2_18795	16	0	50972173	D0401_1_48440	23	1	52471509	D0102_1_19161	19	0
	B0202_5_49540	16	2	50973529	D0601_1_19281	12	0		D0801_1_19338	5	0
31510053	B0501_2_48249	3	1	50974039	D0201_2_48405	18	1	52471513	D0102_1_19161	15	0
34110031	D0701_2_48498	32	1	51171641	G0101_1_19551	1	0	52471516	D0102_1_19161	16	0
34211030	D0901_1_19362	3	0	51172684	D0701_2_48498	7	1	52472430	D1101_1_19419	11	0
34211054	D1101_1_19419	5	0	51172716	D0301_1_19222	1	0	52472646	D0501_1_19263	4	0
35111047	G0202_2_48619	14	1	51172830	G0202_2_48619	8	1	52472651	D0501_1_19263	6	0
35111052	C0202_2_48288	27	4	51172832	G0202_2_48619	15	1	52472654	D0501_1_19263	7	0
35111063	D0102_1_19161	11	0	51172965	B0101_2_18644	12	0	52472657	D0601_1_19281	16	0
35111080	D0102_1_19161	26	0	51172967	C0102_1_19033	1	0	52472659	D0501_1_19263	16	0
	D0801_1_19338	16	0	51173545	C0301_1_19119	1	0	52472700	D0801_1_19338	4	0
35121014	D0701_2_48498	26	1	51173547	C0301_1_19119	5	0	52472701	D0801_1_19338	3	0
	D0901_1_19362	26	0	51174104	C0301_1_19119	4	0	52472711	D0801_1_19338	18	0
35121025	C0202_2_48288	26	2		G0203_1_48686	11	1	52472712	D0801_1_19338	19	0
35121028	D0301_1_19222	7	0	51175011	L0201_0_19826	1.2	0	52472852	D0601_1_19281	21	0



SPARE PARTS INSTANCE INDEX

Code	Parts Table	Pos.	Q.ty	Code	Parts Table	Pos.	Q.ty	Code	Parts Table	Pos.	Q.ty
52472928	D0601_1_19281	8	0	56075715	M0102_2_48797	3.1	1	56172770	G0303_1_19742	15	0
52472933	D1001_2_48472	2	1		M0102_2_48797	9.1	1	56172905	G0101_1_19551	10	0
52473449	C0202_2_48288	25	1	56075970	M0102_2_48797	3.2	1		G0203_1_48686	5	1
52473521	D1001_2_48472	14	1		M0102_2_48797	9.2	1	56172917	G0202_2_48619	51	1
52474123	D1001_2_48472	6	1	56170017	G0101_1_19551	14	0	56172929	A0201_1_18536	7	0
52474190	D1001_2_48472	1	1	56170226	C0202_2_48288	14	1	56172964	B0202_2_18795	37	0
52475450	D0601_1_19281	11	1	56170275	A0501_2_47963	6	1	56172985	A0401_1_18577	12	0
52476787	D0601_1_19281	15	1	56170350	G0202_2_48619	49	1	56172992	A0401_1_18577	11	0
52476788	D0501_1_19263	11	1	56171237	B0701_1_18971	8	0	56172993	A0401_1_18577	13	0
52477270	D0102_1_19161	23	1	56171671	D0102_1_19161	7	0	56172998	A0401_1_18577	5	0
52477271	D0102_1_19161	24	1	56171672	D0102_1_19161	9	0	56173009	A0101_1_18484	9	0
55170053	D0701_2_48498	5	2	56171775	A0501_2_47963	12	1		A0102_1_18510	9	0
55172608	C0202_2_48288	38	2	56171788	L0101_1_19795	25	0	56173012	A0301_1_47945	5	1
55172994	A0301_1_47945	11	1	56171789	L0101_1_19795	24	0	56173013	A0401_1_18577	7	0
55172995	A0301_1_47945	10	1	56171877	A0201_1_18536	3	0	56173058	A0101_1_18484	2	0
55172997	A0401_1_18577	4	0	56171883	A0201_1_18536	4	0		A0102_1_18510	2	0
55174021	D0201_2_48405	12	1	56171936	D0401_1_48440	31	1	56173065	A0101_1_18484	15	0
55174163	D0701_2_48498	3	2	56171938	B0202_5_49540	50	2		A0102_1_18510	15	0
55271644	B0501_2_48249	2/2	1		E0201_2_49124	18	1	56173204	A0101_1_18484	14	0
55271852	B0501_2_48249	2/1	1	56171967	F0102_1_19533	6	0		A0102_1_18510	14	0
55273089	A0501_2_47963	1	1	56172009	D0901_1_19362	7	0	56173447	C0202_2_48288	39	2
55274441	B0501_2_48249	1	1	56172079	D1001_2_48472	16	1	56173496	G0202_2_48619	46	1
56071681	B0101_2_18644	10	0	56172080	D1001_2_48472	17	1	56173497	C0202_2_48288	44	1
56071684	B0101_2_18644	7	0	56172129	B0202_2_18795	43	0	56173511	G0202_2_48619	31	1
56071768	A0201_1_18536	14	0		B0202_5_49540	43	1	56173748	E0101_4_49162	3	2
56072918	L0101_1_19795	7	0	56172163	C0202_2_48288	41	2	56173884	C0202_2_48288	15	2
56072919	L0101_1_19795	6	0	56172643	D0201_2_48405	8	1	56174135	B0202_5_49540	32	2
56073094	D0401_1_48440	25	1	56172685	C0301_1_19119	10	0	56174160	E0101_4_49162	8	1
56073438	B0202_2_18795	25	0	56172719	D0301_1_19222	4	0	56174427	B0101_2_18644	1.2	0
	B0202_5_49540	25	1	56172750	G0303_1_19742	8	0	56174873	B0101_2_18644	15	0
56073439	B0202_2_18795	24	0	56172769	G0202_2_48619	28	1	56175540	B0202_5_49540	34	2
	B0202_5_49540	24	1		G0302_1_19731	7	0	56176373	G0202_2_48619	56	1
56074020	D0201_2_48405	11	1		G0303_1_19742	16	0	56176795	D0701_2_48498	30	1
56075018	L0201_0_19826	1.1	0	56172770	G0302_1_19731	8	0	56177693	B0101_2_18644	1.1	1



SPARE PARTS INSTANCE INDEX

Code	Parts Table	Pos.	Q.ty	Code	Parts Table	Pos.	Q.ty	Code	Parts Table	Pos.	Q.ty
56178591	B0603_0_51086	14	1	56371994	D0102_1_19161	18	0	56571824	L0101_1_19795	1	0
56179398	C0102_1_19033	13	1		D0801_1_19338	7	0	56572694	D0801_1_19338	6	0
56179424	D0201_2_48405	26	1	56372067	L0101_1_19795	26	0	56572720	D0301_1_19222	3	0
56349629	D0401_1_48440	5	1	56372674	D0901_1_19362	21	0	56573708	M0102_2_48797	4	5
56370018	D0701_2_48498	9	4	56372696	D0901_1_19362	33	0		M0201_1_49600	4	5
56370081	C0102_1_19033	6	0	56372702	D0801_1_19338	13	0	57174884	A0501_2_47963	1.3	1
56370172	D0701_2_48498	11	2	56372703	D0801_1_19338	13	0	57370321	B0701_1_18971	4	0
56370178	C0202_2_48288	13	1	56372704	D0801_1_19338	13	0	57371825	A0401_1_18577	6	0
	D0601_1_19281	18	0	56372705	D0801_1_19338	13	0	57371900	A0501_2_47963	2	1
56370228	C0202_2_48288	1.1	2	56372706	D0801_1_19338	13	0	57372600	B0501_2_48249	21.1	1
	G0101_1_19551	16	0	56372708	D0901_1_19362	29	0	57373097	B0101_2_18644	2	0
56371210	L0101_1_19795	29	0	56372774	D0701_2_48498	13	1	57373101	B0501_2_48249	13	1
56371222	B0701_1_18971	6	0	56372775	D0701_2_48498	14	1	57373231	E0201_2_49124	2	1
56371582	C0102_1_19033	9	0	56372776	D0701_2_48498	15	1	57373745	B0202_2_18795	10	0
56371583	C0102_1_19033	9	0	56372831	G0202_2_48619	6	1	57373746	B0202_2_18795	9	0
56371584	C0102_1_19033	9	0	56372925	L0101_1_19795	19	0	57374196	B0501_2_48249	6	1
56371585	C0102_1_19033	9	0	56373348	D0401_1_48440	13	1	57374207	B0202_2_18795	19	0
56371586	C0102_1_19033	9	0	56373440	D0601_1_19281	17	0		B0202_5_49540	19	1
56371652	D0601_1_19281	2	0	56373542	C0202_2_48288	12	1	57374208	B0202_2_18795	20	0
56371656	D0601_1_19281	4	0	56376791	D0601_1_19281	19	1		B0202_5_49540	20	1
56371657	D0601_1_19281	4	0	56376796	D0701_2_48498	16	1	57375344	B0202_5_49540	9	1
56371658	D0601_1_19281	4	0	56377980	L0201_0_19826	1.4	1	57375345	B0202_5_49540	10	1
56371659	D0601_1_19281	4	0	56470365	D0201_2_48405	19	1	58048002	A0201_1_18536	11	0
56371660	D0601_1_19281	4	0		D0401_1_48440	22	1	58070097	B0202_5_49540	35	2
56371661	D0601_1_19281	17	0	56471508	D0102_1_19161	17	0	58070164	D0701_2_48498	10	2
56371662	D0601_1_19281	17	0		D0801_1_19338	8	0	58070168	D0701_2_48498	12	2
56371663	D0601_1_19281	17	0	56471645	C0202_2_48288	24	1	58070169	D0701_2_48498	4	1
56371664	D0601_1_19281	17	0	56471655	D0601_1_19281	5	0	58070198	D0901_1_19362	36	0
56371666	D0102_1_19161	4	0	56471665	D0102_1_19161	5	0	58070205	D0901_1_19362	24	0
56371667	D0102_1_19161	12	0	56472695	D0801_1_19338	9	0	58070390	B0701_1_18971	7	0
56371668	D0102_1_19161	12	0	56472698	D0801_1_19338	11	0	58070489	A0201_1_18536	10/6	0
56371669	D0102_1_19161	12	0	56477572	G0202_2_48619	57	1	58070741	D0701_2_48498	22	4
56371670	D0102_1_19161	12	0	56571697	D0701_2_48498	24	2		D1101_1_19419	7	0
56371777	D0901_1_19362	16	0	56571785	G0101_1_19551	5	0	58071534	G0101_1_19551	9	0

SPARE PARTS INSTANCE INDEX

Code	Parts Table	Pos.	Q.ty	Code	Parts Table	Pos.	Q.ty	Code	Parts Table	Pos.	Q.ty
58071534	G0203_1_48686	4	1	58073549	B0401_2_48226	1	1	58170803	C0202_2_48288	29	1
58071790	C0102_1_19033	5	0	58073550	B0401_2_48226	3/1	2	58170930	F0102_1_19533	14	0
58071805	G0101_1_19551	18	0	58073551	B0401_2_48226	3/2	2	58170968	B0202_2_18795	41	0
58071811	D0901_1_19362	14	0	58073552	B0401_2_48226	4/2	2		B0202_5_49540	47	1
58071998	L0101_1_19795	5	0	58073553	B0401_2_48226	4/1	2	58171596	D0201_2_48405	24	1
58072045	G0101_1_19551	19	0	58073554	B0401_2_48226	5	3		D0401_1_48440	17	1
58072074	A0201_1_18536	10/3	0	58074023	E0201_2_49124	3	1	58171633	A0101_1_18484	1.5	0
58072075	A0201_1_18536	10/5	0	58074024	E0201_2_49124	4	1		A0102_1_18510	1.5	0
58072138	G0303_1_19742	20	0	58074224	B0401_2_48226	6	1	58171861	G0101_1_19551	2	0
	I0101_1_19774	10	0	58074225	B0401_2_48226	7	1	58172011	G0202_2_48619	27.02.00	1
58072269	G0203_1_48686	16	1	58074562	B0401_2_48226	8/1	1		G0302_1_19731	2	0
58072492	A0201_1_18536	10/4	0	58074563	B0401_2_48226	8/2	1		G0303_1_19742	1.2	0
58072509	B0401_2_48226	13	1	58075372	G0203_1_48686	1	1		I0101_1_19774	1	0
58072510	B0401_2_48226	16	1	58075373	G0202_2_48619	53	1	58172012	G0303_1_19742	1.3	0
58072511	B0401_2_48226	15	1	58077816	B0501_2_48249	15	1		I0101_1_19774	3	0
58072517	B0401_2_48226	14	1		E0201_2_49124	5	1	58172013	I0101_1_19774	4	0
58072520	B0401_2_48226	11	2	58078987	E0201_2_49124	7	1	58172014	I0101_1_19774	5	0
58072575	B0401_2_48226	12	1	58078988	E0101_4_49162	1	1	58172015	G0202_2_48619	26	1
58072642	L0101_1_19795	16	0	58078989	E0101_4_49162	5	2	58172016	G0302_1_19731	4	0
58072688	D0201_2_48405	7	1	58078990	E0201_2_49124	16	1		G0303_1_19742	5/2	0
58072737	B0401_2_48226	9	1	58078991	E0201_2_49124	17	1	58172043	B0501_2_48249	11	1
58072795	I0101_1_19774	12	0	58078992	E0201_2_49124	15	1	58172267	B0501_2_48249	15.4	1
58072796	I0101_1_19774	13	0	58170013	C0202_2_48288	23	1		E0201_2_49124	5.4	1
58072922	L0101_1_19795	15	0	58170021	C0301_1_19119	2	0	58172489	G0202_2_48619	27.03.00	1
58072931	A0201_1_18536	10/1	0	58170054	D0701_2_48498	6	1		G0302_1_19731	3	0
58073085	A0201_1_18536	10/2	0	58170077	C0202_2_48288	21	2		G0303_1_19742	3	0
58073147	G0202_2_48619	21	1	58170352	G0202_2_48619	50	1		I0101_1_19774	9/1	0
58073156	B0401_2_48226	17	2	58170376	B0501_2_48249	12	1	58172490	G0202_2_48619	27.04.00	3
58073227	A0201_1_18536	13	0	58170449	L0101_1_19795	11	0		G0303_1_19742	5/1	0
58073237	A0501_2_47963	16	1	58170453	B0501_2_48249	15.3	1	58172707	I0101_1_19774	2	0
58073238	A0501_2_47963	18	1		E0201_2_49124	5.3	1	58172717	D0301_1_19222	2	0
58073498	F0102_1_19533	10	0	58170571	E0201_2_49124	7.1	1	58172718	D0301_1_19222	5	0
58073499	F0102_1_19533	11	0	58170572	E0201_2_49124	7.2	1	58172911	G0202_2_48619	1	1
58073548	B0401_2_48226	2	1	58170634	B0202_2_18795	38	0	58172914	G0202_2_48619	7	1



SPARE PARTS INSTANCE INDEX

Code	Parts Table	Pos.	Q.ty	Code	Parts Table	Pos.	Q.ty	Code	Parts Table	Pos.	Q.ty
58172915	G0202_2_48619	17	1	58175051	A0301_1_47945	1.2	1	59072675	D0901_1_19362	22	0
58172946	D0901_1_19362	12	0	58175052	A0301_1_47945	1.1	1	59072678	D0901_1_19362	17	0
58172957	D0201_2_48405	1	1	58175971	M0201_1_49600	3.2	1	59072722	G0101_1_19551	12	0
58172958	D0201_2_48405	1.1	1	58176203	M0201_1_49600	6/1	1		G0203_1_48686	10	1
58172996	A0401_1_18577	1	0	58176204	M0201_1_49600	6/2	1	59072731	D0701_2_48498	20	1
58172999	A0401_1_18577	1.1	0	58176970	D0201_2_48405	17/2	1	59072754	D1101_1_19419	1	0
58173010	A0101_1_18484	8	0	58176971	D0201_2_48405	17/1	1	59072761	D1101_1_19419	4	0
	A0102_1_18510	8	0	58177722	B0602_1_49108	1	1	59072786	G0303_1_19742	10	0
58173108	B0501_2_48249	14	1	58177728	B0601_1_18928	1	1	59072787	G0303_1_19742	13	0
58173162	G0202_2_48619	27	1	58178704	A0301_1_47945	1	1	59072825	G0101_1_19551	7	0
58173164	F0102_1_19533	1	0	58178909	M0201_1_49600	3/2	1	59072829	G0101_1_19551	6	0
58173187	A0501_2_47963	3	1	58178910	M0201_1_49600	3/1	1	59072848	D0401_1_48440	2	1
58173230	E0201_2_49124	13	1	58178960	D0401_1_48440	20	1	59072859	D0401_1_48440	1	1
58173337	G0202_2_48619	45	1	58179168	D0102_1_19161	1	1	59072903	A0201_1_18536	12/1	0
58173358	M0201_1_49600	3.1	1	58192377	B0602_1_49108	3	1	59072904	D0401_1_48440	7	1
58173361	G0303_1_19742	1.4	0		B0603_0_51086	13	1	59072913	L0101_1_19795	4/1	0
	I0101_1_19774	9/2	0	59070448	L0101_1_19795	12	0	59072940	B0202_2_18795	33	0
58173437	B0603_0_51086	4	1	59070591	B0202_5_49540	41	1	59072945	B0202_2_18795	35	0
58173442	A0102_1_18510	1.4	0	59070592	B0202_2_18795	42	0	59072974	F0102_1_19533	2	0
58173507	G0202_2_48619	43/1	1		B0202_5_49540	42	1	59073003	D0901_1_19362	27	0
58173515	G0202_2_48619	43/2	1	59071171	C0202_2_48288	17	1	59073007	A0101_1_18484	7	0
58173518	G0202_2_48619	27.01.00	1	59071241	B0602_1_49108	13	1	59073008	A0102_1_18510	7	0
	G0302_1_19731	1	0	59071518	D0102_1_19161	21	0	59073090	A0501_2_47963	9	1
	G0303_1_19742	1.1	0	59071743	B0701_1_18971	2	0	59073093	D0401_1_48440	26	1
	I0101_1_19774	8	0	59071745	B0701_1_18971	5	0	59073098	B0101_2_18644	3	0
58173519	G0303_1_19742	1	0	59071778	D0901_1_19362	13	0	59073128	B0202_2_18795	28	0
58173616	A0101_1_18484	11	0	59071779	D0901_1_19362	15	0	59073129	B0202_2_18795	29	0
	A0102_1_18510	11	0	59072006	D0901_1_19362	6	0	59073139	B0202_2_18795	31	0
58173642	G0202_2_48619	45.02.00	1	59072007	D0901_1_19362	5	0	59073320	G0202_2_48619	35	1
58174019	F0102_1_19533	15	0	59072008	D0901_1_19362	1	0	59073429	A0201_1_18536	12/2	0
58174093	A0301_1_47945	2	2	59072057	G0202_2_48619	30	2	59073430	B0202_2_18795	17	0
58174192	D0701_2_48498	1	2		G0303_1_19742	4	0		B0202_5_49540	17	1
58174451	M0102_2_48797	9/1	1	59072114	B0202_5_49540	48	1	59073431	B0202_2_18795	18	0
58174453	M0102_2_48797	9/2	1	59072408	G0202_2_48619	44	1		B0202_5_49540	18	1



SPARE PARTS INSTANCE INDEX

Code	Parts Table	Pos.	Q.ty	Code	Parts Table	Pos.	Q.ty	Code	Parts Table	Pos.	Q.ty
59073491	L0101_1_19795	4/2	0	59275709	M0102_2_48797	3/2	1	59900183	B0603_0_51086	5	1
59073500	C0202_2_48288	34	1	59275710	M0102_2_48797	3/1	1	59900184	B0603_0_51086	6	1
59073509	D0901_1_19362	30	0	59372713	D0102_1_19161	13	0	59900185	B0603_0_51086	7	1
59073514	D0201_2_48405	22/2	1	59372819	D0501_1_19263	2/1	0	59900186	B0603_0_51086	8	1
59073599	D0401_1_48440	16	1	59373451	D0501_1_19263	2/2	0	59900187	B0603_0_51086	9	1
59073600	D0401_1_48440	15	1	59373537	D0801_1_19338	1	0	59900192	A0101_1_18484	1.1	0
59073604	D0201_2_48405	22/1	1	59375017	L0201_0_19826	1	0		A0102_1_18510	1.1	0
59073799	B0202_2_18795	40	0	59900152	B0602_1_49108	15	1	59900193	A0101_1_18484	1.2	0
59073888	B0202_2_18795	3	0	59900153	B0602_1_49108	9	1		A0102_1_18510	1.2	0
59074089	G0202_2_48619	25	1	59900154	B0602_1_49108	8	4	59900194	A0102_1_18510	1.3	0
59074105	G0203_1_48686	7	1	59900155	B0602_1_49108	7	1	59900199	B0603_0_51086	1	1
59074140	B0202_5_49540	4	1	59900156	B0602_1_49108	6	1	59900217	A0401_1_18577	1.2	0
59074141	B0202_5_49540	33	1	59900157	B0602_1_49108	11	1	59900218	A0401_1_18577	1.3	0
59074144	B0202_5_49540	3	1	59900158	B0602_1_49108	10	18	59900219	A0401_1_18577	1.4	0
59074187	D0701_2_48498	34	1	59900159	B0602_1_49108	5	1	59900220	A0401_1_18577	1.5	0
59074862	B0202_2_18795	1	0	59900160	B0602_1_49108	12	1	59900222	A0101_1_18484	1.6	0
59074863	B0202_2_18795	2	0	59900161	B0602_1_49108	14	1		A0102_1_18510	1.6	0
59074878	G0202_2_48619	40	1	59900163	B0601_1_18928	9	0	59900223	A0101_1_18484	1.3	0
59075012	L0201_0_19826	1.3	0	59900165	B0601_1_18928	15	0	59900226	D0201_2_48405	1.2	1
59075077	D1001_2_48472	15	1	59900166	B0601_1_18928	14	0	59900227	A0101_1_18484	1.4	0
59075283	B0101_2_18644	21	1	59900167	B0601_1_18928	12	0	59900247	F0102_1_19533	15.2	1
59075386	G0202_2_48619	54	1	59900168	B0601_1_18928	10	0	59900267	B0101_2_18644	1/1	0
59075490	B0202_5_49540	31	1	59900169	B0601_1_18928	11	0	59900268	B0101_2_18644	1/2	0
59075504V	B0202_5_49540	1	1	59900170	B0601_1_18928	13	0	59900269	B0101_2_18644	1/3	0
59075508V	B0202_5_49540	2	1	59900171	B0601_1_18928	2	0	59900270	B0101_2_18644	1/4	0
59076413	B0202_5_49540	51	1	59900172	B0601_1_18928	5	0	59900540	A0301_1_47945	15	1
59076414	B0202_5_49540	52	1	59900173	B0601_1_18928	6	0	59901049	B0602_1_49108	4	1
59076793	D0701_2_48498	2	2	59900174	B0601_1_18928	7	0	59901050	B0602_1_49108	2	1
59076794	D0701_2_48498	28	1	59900175	B0601_1_18928	8	0	59901266	B0601_1_18928	16	1
59078975V	B0202_5_49540	28	1	59900178	F0102_1_19533	15.1	0	59978068	D0701_2_48498	33	1
59078980V	B0202_5_49540	29	1	59900180	G0101_1_19551	9.2	0	F0010001078	B0701_1_18971	1	0
59078986	B0202_5_49540	53	2		G0203_1_48686	4.2	1	F0060031247	L0101_1_19795	10	0
59079661	D0201_2_48405	27	1	59900181	G0101_1_19551	9.1	0	F0150010905	M0102_2_48797	8	1
59275173	C0202_2_48288	1	1		G0203_1_48686	4.1	1		M0201_1_49600	6.1	1

SPARE PARTS INSTANCE INDEX

Code	Parts Table	Pos.	Q.ty	Code	Parts Table	Pos.	Q.ty	Code	Parts Table	Pos.	Q.ty
F0150010910	M0201_1_49600	7	1	F0808060100	L0101_1_19795	22	0	F0814574000	D1001_2_48472	13	6
F0150036216	B0603_0_51086	2	1	F0808518050	B0401_2_48226	10	4		E0201_2_49124	26	1
F0150036219	B0603_0_51086	3	1	F0810505010	D0901_1_19362	11	0	F0814627000	D0201_2_48405	15	1
F0190031203	L0101_1_19795	21	0	F0810510000	D0201_2_48405	21	1		D0401_1_48440	24	1
F0190035152	E0201_2_49124	22	1		D0401_1_48440	11	1	F0814629010	B0101_2_18644	9	0
F0252929002	B0101_2_18644	19	0	F0810527000	D0901_1_19362	31	0	F0814642020	B0202_2_18795	45	0
F0256808000	B0202_2_18795	27	0	F0812523050	D0201_2_48405	2	1		B0202_5_49540	45	2
	B0202_5_49540	27	1		G0202_2_48619	5	1	F0814647000	B0101_2_18644	5	0
F0256809050	A0301_1_47945	13	1	F0812525100	D1001_2_48472	3	1		C0202_2_48288	5	2
F0256910000	B0101_2_18644	14	0	F0812686100	D0601_1_19281	20	0	F0814688010	G0202_2_48619	16	1
F0801095000	D0401_1_48440	27	1	F0812689000	D0501_1_19263	3	0	F0814695000	C0301_1_19119	7	0
F0801127050	G0202_2_48619	4	1		D0601_1_19281	6	0		G0203_1_48686	13	1
F0801149010	G0101_1_19551	11	0	F0812733075	D0501_1_19263	13	0	F0814744050	E0201_2_49124	14	1
	G0203_1_48686	6	1		D0601_1_19281	10	0	F0814751000	M0102_2_48797	3.4	4
F0801151000	D0501_1_19263	9	0	F0812747000	C0202_2_48288	20	2		M0102_2_48797	9.4	4
F0801185010	D0401_1_48440	6	1	F0812779000	D1001_2_48472	5	1		M0201_1_49600	3.4	4
F0801190000	D0301_1_19222	8	0	F0812810100	D0601_1_19281	3	0	F0817505000	A0501_2_47963	17	1
F0801241005	D0601_1_19281	7	0	F0812849100	D0501_1_19263	1	0	F0817512000	A0501_2_47963	15	1
F0801248000	D0501_1_19263	12	0		D1001_2_48472	8	1	F0817523010	A0301_1_47945	12	4
	D0601_1_19281	9	0	F0812871030	D0501_1_19263	10	0		G0202_2_48619	42	4
F0801264050	D1001_2_48472	7	1	F0812895000	C0102_1_19033	8	0	F0817568000	A0401_1_18577	3	0
	G0101_1_19551	8	0	F0812895100	D0801_1_19338	12	0	F0817603000	A0401_1_18577	2	0
F0801297000	G0303_1_19742	26	0	F0812933000	D0501_1_19263	14	0	F0817640003	D0701_2_48498	27	2
	I0101_1_19774	19	0	F0814525000	A0101_1_18484	18	0	F0819134030	D0201_2_48405	5	1
F0801331000	D0501_1_19263	5	0		A0102_1_18510	18	0	F0819134040	D0201_2_48405	9	1
F0801331100	D0601_1_19281	14	0	F0814529080	E0101_4_49162	6	4	F0819134050	D0201_2_48405	6	1
F0801425000	D0501_1_19263	15	0		E0201_2_49124	19	1	F0821057000	D0102_1_19161	22	0
F0802100050	C0202_2_48288	32	1	F0814547000	C0202_2_48288	43	4		D0801_1_19338	14	0
F0802190010	D0102_1_19161	8	0	F0814569000	B0601_1_18928	3	0	F0822537050	D0201_2_48405	23	1
	D1001_2_48472	11	1		D0401_1_48440	14	1		D0401_1_48440	3	1
F0802239052	D0102_1_19161	25	0	F0814574000	B0202_2_18795	8	0	F0824110000	G0202_2_48619	18	12
	D0801_1_19338	17	0		B0202_5_49540	8	10		G0303_1_19742	12	0
F0803178000	D0901_1_19362	32	0		C0202_2_48288	31	1		G0303_1_19742	19	0
F0806533000	D0401_1_48440	4	1		D0102_1_19161	2	0		I0101_1_19774	7	0



SPARE PARTS INSTANCE INDEX

Code	Parts Table	Pos.	Q.ty	Code	Parts Table	Pos.	Q.ty	Code	Parts Table	Pos.	Q.ty
F0824141000	F0102_1_19533	8	0	F0831139000	D0201_2_48405	25	1	F0843109020	G0202_2_48619	34	4
	G0202_2_48619	23	4		D0701_2_48498	31	1		G0303_1_19742	11	0
	G0303_1_19742	24	0	F0831193010	D0201_2_48405	16	1	F0843116000	F0102_1_19533	7	0
	I0101_1_19774	17	0	F0834378001	A0101_1_18484	1.7	0		G0202_2_48619	22	2
F0824185000	G0202_2_48619	48	1		A0102_1_18510	1.7	0	F0843561000	A0101_1_18484	17	0
F0825115010	B0501_2_48249	16	1		E0101_4_49162	9	1		A0102_1_18510	17	0
F0825117000	E0201_2_49124	11	1	F0835023000	G0202_2_48619	36	1	F0843570000	A0301_1_47945	7	3
F0825139000	B0501_2_48249	19	1		G0303_1_19742	18	0		A0401_1_18577	8	0
	E0201_2_49124	6	1		I0101_1_19774	6	0		B0202_2_18795	12	0
F0825400060	B0501_2_48249	18	1	F0835024010	G0202_2_48619	19	1		B0202_5_49540	12	4
F0825403050	B0501_2_48249	23	1	F0835040020	G0303_1_19742	23	0		B0501_2_48249	8	1
F0825404050	E0101_4_49162	2	2		I0101_1_19774	16	0		B0701_1_18971	11	0
F0825414000	E0201_2_49124	27	1	F0835040030	F0102_1_19533	9	0		C0102_1_19033	15	1
F0825415050	A0301_1_47945	14	1	F0835523000	D0401_1_48440	9	1		C0202_2_48288	36	8
F0825416000	G0202_2_48619	20	1	F0837521000	B0701_1_18971	9	0		D0201_2_48405	4	1
F0825417000	E0101_4_49162	7	1	F0837534010	D1101_1_19419	6	0		D0901_1_19362	8	0
F0825420560	E0101_4_49162	5.1	1		G0202_2_48619	29	1	F0843578010	C0202_2_48288	37	1
F0825420660	E0201_2_49124	17.1	1		G0302_1_19731	9	0	F0843643060	A0101_1_18484	6	0
F0825436000	B0501_2_48249	15.1	1		G0303_1_19742	17	0		A0102_1_18510	6	0
	E0201_2_49124	5.1	1	F0838131000	A0101_1_18484	12	0		A0201_1_18536	15	0
F0825436003	B0501_2_48249	15.2	1		A0102_1_18510	12	0		A0301_1_47945	4	2
	E0201_2_49124	5.2	1		D1001_2_48472	12	4		A0501_2_47963	8	1
F0825438000	E0201_2_49124	8	1	F0838166018	D1001_2_48472	18	2		B0202_2_18795	7	0
F0825470050	E0201_2_49124	1	1	F0838530150	C0202_2_48288	4	2		B0202_5_49540	7	16
F0825488000	E0201_2_49124	12	1	F0838660000	C0301_1_19119	6	0		C0202_2_48288	19	1
F0825493000	E0201_2_49124	21	1		G0203_1_48686	12	1		D0201_2_48405	29	1
F0825500220	B0501_2_48249	17.1	1	F0840544000	G0202_2_48619	52	1		D0401_1_48440	29	1
F0825718010	G0202_2_48619	45.01.00	1	F0842512000	G0202_2_48619	24	1		D0901_1_19362	18	0
F0825980030	G0303_1_19742	25	0	F0842519050	G0203_1_48686	17	1		D1001_2_48472	19	2
	I0101_1_19774	18	0	F0843107000	G0202_2_48619	37	1		D1101_1_19419	2	0
F0826056000	C0202_2_48288	10	2		G0203_1_48686	8	2		E0201_2_49124	24	1
	G0101_1_19551	3	0		G0303_1_19742	21	0		G0202_2_48619	3	10
	L0201_0_19826	1.6	0		I0101_1_19774	14	0		G0202_2_48619	27.05.00	1
F0828029070	A0201_1_18536	1	0	F0843109000	F0102_1_19533	12	0		G0302_1_19731	5	0

SPARE PARTS INSTANCE INDEX

Code	Parts Table	Pos.	Q.ty	Code	Parts Table	Pos.	Q.ty	Code	Parts Table	Pos.	Q.ty
F0843643060	G0303_1_19742	7	0	F0848629000	M0201_1_49600	1	1	F0862495010	B0603_0_51086	11	4
	L0101_1_19795	14	0	F0848635000	M0102_2_48797	6	1	F0862593050	C0202_2_48288	30	1
F0843696000	B0603_0_51086	12	6	F0848649000	M0102_2_48797	7	1	F0862657000	D0102_1_19161	3	0
	D0201_2_48405	30	1	F0848887000	M0102_2_48797	2	1	F0862694000	D0701_2_48498	8	4
F0843708000	E0201_2_49124	25	1	F0849206005	A0301_1_47945	8	1	F0863079000	G0202_2_48619	2	2
F0843755000	A0501_2_47963	11	1	F0849211010	B0101_2_18644	6	0	F0863097070	A0501_2_47963	5	1
	B0101_2_18644	8	0	F0849500001	A0501_2_47963	1.1	1	F0863183000	D0701_2_48498	25	2
	B0202_2_18795	23	0	F0849500002	A0501_2_47963	1.2	1	F0863217060	D0401_1_48440	18	1
	B0202_5_49540	23	8	F0851180000	D0701_2_48498	21	4	F0863267050	C0202_2_48288	8	8
	C0202_2_48288	3	1	F0851260000	D0901_1_19362	23	0		D0102_1_19161	14	0
	C0301_1_19119	12	0	F0851267050	D0901_1_19362	35	0		D0801_1_19338	2	0
	D0201_2_48405	10	1	F0851486000	L0101_1_19795	17	0	F0863276000	G0202_2_48619	41	2
	D0401_1_48440	19	1		L0201_0_19826	1.5	0	F0863328000	G0101_1_19551	13	0
	F0102_1_19533	4	0	F0851497000	B0101_2_18644	22	1	F0863359000	C0202_2_48288	2	1
	G0202_2_48619	10	4		L0101_1_19795	23	0		G0202_2_48619	12	1
	L0101_1_19795	9	0	F0852550010	G0303_1_19742	27	0	F0863449000	G0202_2_48619	9	1
F0843843060	B0101_2_18644	17	0		I0101_1_19774	20	0	F0863951000	B0101_2_18644	13	0
	B0202_5_49540	39	12	F0858021000	A0201_1_18536	8	0	F0864176000	M0102_2_48797	5/1	5
	L0101_1_19795	28	0	F0858520000	A0201_1_18536	17	1		M0201_1_49600	5/1	5
F0843907000	G0202_2_48619	38	2	F0859070030	B0101_2_18644	20	1	F0864192000	M0102_2_48797	5/2	5
	G0203_1_48686	9	4	F0860058000	D0201_2_48405	14	1		M0201_1_49600	5/2	5
	G0303_1_19742	22	0	F0860060010	D0401_1_48440	8	1	F0864200000	M0102_2_48797	3.5	4
	I0101_1_19774	15	0	F0860060020	D0401_1_48440	12	1		M0102_2_48797	9.5	4
F0843948000	F0102_1_19533	13	0	F0861867050	A0501_2_47963	4	1		M0201_1_49600	3.5	4
F0843957000	D0901_1_19362	25	0	F0861929060	A0101_1_18484	16	0	F0864309100	B0202_5_49540	36	2
F0844065010	L0101_1_19795	20	0		A0102_1_18510	16	0	F0864364000	M0102_2_48797	11/1	1
F0844084000	M0102_2_48797	12	1	F0861941000	E0201_2_49124	9	1	F0864403000	M0102_2_48797	11/3	1
F0844179010	L0101_1_19795	18	0	F0862037050	D0601_1_19281	13	0	F0865040000	B0501_2_48249	20	1
F0844273090	C0102_1_19033	7	0	F0862210000	C0202_2_48288	42	4	F0865040010	B0501_2_48249	22	1
	C0301_1_19119	3	0	F0862479020	B0501_2_48249	4	1	F0865475000	B0501_2_48249	21	1
F0844283020	L0101_1_19795	2	0	F0862479040	B0101_2_18644	4	0	F0907170109	B0401_2_48226	18	1
F0847434000	D0701_2_48498	23	4	F0862481000	B0701_1_18971	10	0	F1000005108	E0101_4_49162	4	6
	D1101_1_19419	8	0	F0862488000	E0201_2_49124	23	1	P241171000000	G0202_2_48619	33	1
F0848610000	M0102_2_48797	1	1		L0101_1_19795	3	0	P295332000000	D0901_1_19362	2	0

SPARE PARTS INSTANCE INDEX

Code	Parts Table	Pos.	Q.ty
P470330000000	D1001_2_48472	21	1
P470433000000	D1001_2_48472	20	1